

Preface

Thank you for purchasing A90 series inverter.

Document No.: 31010136

Issue Date:2017-10

Version:100

A90 series inverter of SINEE is a high reliability ,small size inverter that supports: 3-phase AC induction motor and permanent magnet synchronous motor; multiple internationally leading drive control technologies, including vectored V/F control technology (VVF) and sensorless vector control technology (SVC); speed and torque control.

A90 is suitable for air compressor, extruder, fan, pump application etc.

Main features:

- 50°C ambient temperature, full load running;
- One of the smallest size series;
- Wide speed regulation range and high control precision: VF/1:50, SVC/1:200 and $\pm 0.2\%$ rated speed;
- Loading capacity at low frequency: VF/1Hz/150% and SVC/0.25Hz/150%;
- Protection function: over-current, over-voltage, overload, overheating and other multiple protection.

Please read this guide carefully before using A90 inverter and keep it properly.

Before connecting inverter and a motor for the first time, please select proper motor type (asynchronous motor or synchronous motor) and configure motor nameplate parameters including rated power, rated voltage, rated current, rated frequency, rated rotation speed.

Since SINEE is committed to the development and improvement of products and product documents, this guide will be updated without notice.

Latest updates and additional information are available at

www.sineedrive.com.

Safety Information

In this guide, there are two types of safety information.



Danger: The label indicates that a failure to follow instructions can result in serious injury or even death.



Caution: The label indicates that a failure to follow instructions can result in moderate or slight injury and device damage.

Please read this chapter carefully before system installation, debugging and maintenance and always follow the safety precautions below during operation. SINEE will not undertake any damage or loss caused by a failure to follow the instructions.

Safety Precautions

Before Installation:



Danger

1. Do not install inverter if its package is wetted or any its component is missing or broken.
2. Do not install inverter if the label information on its package is not identical to that on inverter.



Caution

1. Open the wooden box, please bring gloves, do not hand contact the wooden box on the sealed iron, or the risk of injury!
2. when handling the inverter, be sure to grasp the bottom of the inverter. If you hold the front cover, the inverter body may fall, there is the risk of being injured!
3. Be careful when carrying or transporting inverter so as to avoid damage!
4. Do not use inverter if it is damaged or any component is missing so as to avoid injury!
5. Do not touch the parts of control system with bare hands so as to avoid ESD!
6. the inverter has been Dielectric Withstand Voltage Test in the factory, do not carry on the Dielectric Withstand Voltage Test of the inverter, otherwise there is danger of damage to the inverter!

During Installation:



Danger

1. Installation base shall be metal or other non-flammable material so as to prevent fire risk.
2. Do not unscrew fixing bolts, especially bolts with red mark.



Caution

1. Can not be installed in the inverter with conductive dust, corrosive gases, salt spray, oil, condensation, vibration or direct sunlight occasions!
2. Ensure that no cable strips or screws are dropped into inverter so as to avoid damage to inverter.
3. Consider the installation space for cooling purpose when inverter is installed in a closed cabinet or space.

Wiring:

	Danger
<p>1.Wiring must be performed by authorized and qualified personnel so as to avoid unexpected accidents.</p> <p>2.Between the inverter and the power supply must be separated from the circuit breaker (recommended to use greater or equal to and the nearest 2 times the rated current specifications), or it may fire!</p> <p>3.Please confirm the power before the line is disconnected (zero energy) state, do not live for wiring work, or there is the risk of electric shock!</p> <p>4.Never connect input power supply cable to output terminals (U, V ,W)of inverter. Pay attention to terminal symbols and connect to the terminals correctly. Otherwise it will cause damage to the inverter, and even cause a fire!</p> <p>5. Please follow the standard on the inverter for the correct and reliable grounding, otherwise there will be the risk of electric shock!</p>	

	Caution
<p>1.Connect the inverter output terminals U, V, and W to the motor input terminals U, V and W, respectively. Phase sequence inconsistency can cause the motor to reverse.</p> <p>2.Be sure that wiring meets EMC requirements and local safety standards. Cable should be in recommended sizes so as to prevent accident risk.</p> <p>3.Must not be directly connected brake resistor to DC bus terminals + and – so as to prevent fire risk.will cause a fire!</p> <p>4.Tighten terminals with a screwdriver of specified torque so as to prevent fire risk.</p> <p>5.Do not connect a phase-shifting capacitor or an LC/RC noise filter to output circuits.</p> <p>6.Do not connect the electromagnetic switch, electromagnetic contactor to the output circuit, otherwise the inverter over-current protection circuit action, serious, will lead to internal damage to the inverter.</p> <p>7.Do not disconnect internal cable of inverter, or else this can possibly damage the internal parts of inverter.</p>	

Before Power-on:

	Danger
<p>1.Please confirm whether the input power supply voltage level and inverter rated voltage level, otherwise it will lead to equipment damage or cause a fire;</p> <p>2. Confirm the power input terminal (R, S, T), and the output terminals (U, V, W) on the connection position is correct;</p> <p>3. Pay attention to check with the inverter connected to the external circuit is short-circuit phenomenon, the connection line is fastened, otherwise it will cause the inverter damage!</p>	

	Caution
<p>1.The front cover of inverter must be closed before inverter is powered on. Otherwise, it may result in an electric shock.</p> <p>2.The wiring of all peripherals must be conducted in accordance with the guidance of this guide. Otherwise, it may result in an electric hazard.</p>	

After Power-on:



Danger

1. Do not touch inverter or its peripheral circuits with wet hands to avoid the electric shock.
2. If the indicator is off or the keypad does not display any information after power-on, please cut off the power supply immediately. After 10 minutes of power outages, check wiring for errors. Never touch any terminal of R, S or T of inverter or the connecting terminals with hands or a screw driver, or else an electric shock accident may occur. Contact our customer service personnel immediately after cutting off the power.
3. After power can not touch any terminal of the inverter, must not touch the motor, or there is danger of electric shock.
4. Do not remove any parts of the inverter in the power-on state of the inverter.



Caution

1. If the need for parameter identification, please note that the motor rotation of the risk of injury, please confirm the safety and then proceed, otherwise it may cause accidents!
2. Do not arbitrarily change the inverter manufacturers parameters, otherwise it may cause damage to equipment!

Maintenance:



Danger

1. Do not live on the equipment for maintenance and repair, or there is danger of electric shock!
2. Cut off the main circuit power supply, confirm the keypad display interface extinguished at least 10 minutes before the implementation of the inverter maintenance and repair, or residual capacitor on the capacitor will cause harm!
3. Without the professional training of personnel Do not carry out the maintenance and maintenance of the inverter, or cause personal injury or equipment damage!
4. After the replacement of the inverter must be set and check the parameters, all pluggable interface must be plugged in the case of power failure!
5. The power generated when the synchronous machine running. To wait for the motor to stop 10 minutes after power off, then disconnect the motor and inverter connection, and do a good job in order to implement the maintenance and maintenance of the inverter, otherwise there is a Risk of electric shock!

During Operation:



Danger

1. Never touch cooling fan, heat sink or discharge resistor with bare hands for checking temperature, which may result in burning!
2. Only qualified technicians are allowed to detect signal during operation so as to prevent personal injury or device damage.



Caution

1. Prevent any foreign items from being dropped into the device during operation, so as to avoid damage to the device.
2. Do not control the start/stop of inverter by ON/OFF of the contactor so as to avoid damage to the device.

Attentions

Motor Insulation Inspection

Motor insulation inspection shall be performed before using a motor for the first time or left unused for some time or during routine inspection, in order to avoid damaging inverter due to failure of insulation performance of motor winding. Make sure to disconnect motor cable from inverter during inspection; 500V megohmmeter is recommended. The obtained insulation resistance from test shall not be lower than 5MΩ.

Motor Thermal Protection

If the selected motor does not match with inverter in rated capacity, especially when its rated power is lower than that of inverter, be sure to adjust motor protection parameters of inverter or install a thermal relay in front of the motor to protect the motor.

Operation at Power frequency

Output frequency of inverter ranges from 0.00 Hz to 600.00 Hz. To use inverter at over 50.00 Hz, please consider the bearing capacity of mechanical device.

Motor Heat and Noise

Since output voltage of inverter presents a PWM waveform along with some harmonic waves, the temperature rise, noise and vibration of motor would increase a little in comparison with the running under power frequency.

Varistor or Power Factor Improvement Capacitor on Inverter Output

Inverter outputs PWM wave. Do not use inverter, if a power factor improvement capacitor or a lightning varistor is on output side, which may easily result in transient overcurrent of inverter, or even damage inverter.

Beyond Rated Voltage

Do not use A90 inverter beyond the operating voltage range specified in this guide, which may easily damage its internal parts. If you have to do so, install a voltage rise or reduction device for transformation.

Surge Protection

A surge protection device is installed in inverter to prevent it from induction lightning stroke on a certain degree. Additional protection devices are required in front of inverter in the places where thunder and lightning occur frequently.

Altitude and Derating

When inverter is used in an area at an altitude of over 1,000m, the cooling effect will degrade, so it must be derated. For details, please consult SINEE.

Attentions at Inverter Scrapping

Burning the electrolytic capacitors of the mains and PCB may result in explosion and burning plastic parts may generate toxic gas. Please handle them as industrial wastes when inverter is scrapped.

The scope of use of this product

This product is not designed and manufactured for use in equipment or systems used in the event of a life hazard. Do not use this equipment.

This product is manufactured under strict quality management, but it is necessary to configure the safety device when it is used for equipment that causes a major accident or loss due to a malfunction.

Anti-shock

Please carefully read the safety precautions in the requirements! Cut off the main circuit power supply, confirm the keypad display interface extinguished at least 10 minutes before the implementation of the inverter maintenance and repair, or residual capacitor on the capacitor will cause harm!

CONTENTS

PREFACE	1
SAFETY INFORMATION	2
1 OVERVIEW	7
2 INSTALLATION	10
3 WIRING	14
4 KEYPAD AND DISPLAY	21
4.1 KEYPAD FUNCTION	21
4.2 KEYPAD OPERATION MODE	22
4.3 FAULT MONITORING	25
4.4 RUN MONITORING	25
4.6 RUN/STOP	25
5 QUICK START COMMISSIONING	26
5.1 COMMISSIONING PROCESS	26
5.2 CHECK LIST BEFORE POWER UP	27
5.3 CONFIRM THE STATUS OF THE INVERTER AFTER POWER UP	27
5.4 NOTE ABOUT THE MACRO	27
5.5 START AND STOP CONTROL	27
5.6 FREQUENTLY USED PROCESS PARAMETERS	30
5.7 MOTOR PARAMETER AUTOTUNE	31
6 TROUBLESHOOTING	32
7 MAINTENANCE AND INSPECTION	38
8 OPTIONS	40
9 PARAMETER LIST	42
10 APPLICATION MACRO	66

1 Overview

1.1 A90 Model and Specifications

- Rated voltage: 3-phase, 340~460VAC, single-phase 200~240VAC
- Applicable motor: 3-phase AC induction motor and permanent magnet synchronous motor

Rated Voltage	Model	Motor Power (kW)	Rated output current, Heavy Duty (A)	Rated output current, Normal Duty (A)
Single-phase 200V~240V	A90-2S2R8B	0.4	2.8	3.2
	A90-2S4R8B	0.75	4.8	5.0
	A90-2S008B	1.5	8	8.5
	A90-2S010B	2.2	10	11.5
3-phase 340~460V	A90-4T1R5B	0.4	1.5	1.8
	A90-4T2R5B	0.75	2.5	3
	A90-4T4R2B	1.5	4.2	4.6
	A90-4T5R6B	2.2	5.6	6.5
	A90-4T9R4B	4.0	9.4	10.5
	A90-4T013B	5.5	13	15.7
	A90-4T017B	7.5	17	20.5
	A90-4T025B	11	25	28
	A90-4T032B	15	32	36
	A90-4T038B	18.5	38	41.5
	A90-4T045B	22	45	49
	A90-4T060	30	60	70
	A90-4T075	37	75	85
	A90-4T090	45	90	105
	A90-4T110	55	110	134
	A90-4T150	75	150	168
A90-4T176	90	176		
A90-4T210	110	210		
A90-4T253	132	253		
A90-4T304	160	304		

- ★ The inverter selection method is: inverter rated output current \geq motor rated current, and consider the overload capacity.
- ★ The power difference between inverter and the motor is generally recommended not to exceed two power grade.
- ★ Large inverter with a small motor, be sure to enter the motor parameters correctly, in order to protect the motor when overload.

1.2 A90 inverter technical specifications

Items		Specifications
Input	Rate Voltage Range	3-phase 340V-10%~460V+10%,single-phase 200V-10%~240V+10%, 50~60Hz±5%, voltage unbalance <3%
Output	Maximum Output Voltage	Maximum output voltage is identical to input voltage.
	Rated Output Current	Refer to section 1.1
	Overload Capacity	Heavy Duty: 150% rated current for 60s, 180% rated current for 10s and 200% rated current for 2s Normal Duty: 120% rated current for 60s, 150% rated current for 10s and 180% rated current for 2s
Basic Control Functions	Control Mode	V/F(VVF) and SVC
	Input Mode	Frequency (speed) input and torque input
	Start/Stop Control Mode	Keypad, control terminals (2-wire , 3-wire sequence) and communication control.
	Frequency Control Range	0.00 - 600.00 Hz
	Input Frequency Resolution	Digital input: 0.01 Hz/ 0.1Hz, analog input: 0.1% of maximum frequency
	Speed adjustable range	1:50 (VVF)、1:200 (SVC)
	Speed Control Accuracy	±0.2% rated synchronous speed
	Acceleration, Deceleration Time	0.01-600.00 seconds/0.1 - 6000.0 seconds/1 - 60000 seconds
	V/F Features	Rated output voltage: 20% - 100% adjustable; frequency base: 1 Hz - 600 Hz
	Torque Boost	Fixed torque boost curve, customer defined V/F curve
	Start Torque	150%/1Hz (VVF)、150%/0.25Hz (SVC)
	Torque Control Accuracy	±8% rated torque (SVC)
	AVR	Output voltage remains unchangeable and input voltage varies when AVR is active
	Automatic Current Limit	Automatically limit output current to avoid frequently overcurrent trip.
DC Brake	Brake frequency: 0.01 - Maximum frequency, brake time: 0 -	

A90 series Inverter User Guide

		30S Brake current: 0% - 150% rated current
	Signal Input Source	Communication, preset speed, analog input
Input and Output Terminals	Reference Power Supply	10V/10mA
	Terminal Control Power Supply	24V/100mA
	Digital Input Terminal	6 Digital multi-functional input terminals:X1-X6
	Analog Input Terminal	2 Digital multi-functional input terminals: 1 (AI1) voltage source 0 - 10 input; 1 (AI2) voltage source 0 - 10V inputs or current 0 - 20mA input;
	Digital Output Terminal	1 OC multi-functional outputs and 1 relay multi-functional outputs. Maximum output current of OC: 50mA; Relay contact capacity: 250VAC/3A or 30VDC/1A. EA-EC normally open, EB-EC normally close.
	Analog Output Terminal	1 (M1) 0~10V multi-function analog output terminal, the maximum output current is 2mA
Keypad Display	LED	LED displays relevant informations of inverter.
Protection	Protections	Short circuit protection, overcurrent, overvoltage, undervoltage, phase loss, overload, offload, external fault, etc.
Working Condition	Installation Site	To be installed indoor with an altitude less than 1,000 meters, free from dust, corrosive gas and direct sunlight.
	Ambient Temperature	-10℃ - +50℃, 5% - 95%RH (no condensation)
	Vibration	< 0.5g
	Storage Temperature	-40℃ ~ +70℃
	Installation Method	Wall mounting, Cabinet installation
Protection Degree		IP20/IP21(Add plastic baffle)
Cooling Method		Forced air cooling

2 Installation

2.1 Product Verification

 Danger
<ul style="list-style-type: none"> Do not install inverter if it is damaged or any component is missing so as to avoid injury!

Please verify inverter products as per table 2-1 when you get them.

Table 2-1 Check List

Item	Method
Check if they are identical to the purchase order.	Check the nameplate at the side of inverter.
Any damage.	Check the overall appearance to see if they are damaged in transportation.
Any loosened screws or other fastening parts.	Check with a screwdriver if necessary.

If you find any quality problem, please contact the distributor or SINEE Sale Department.

- Nameplate**

MODEL: A90-4T9R4B

INPUT:
U1: 3PH 340-460V 50/60Hz I1: 11.2A

OUTPUT:
U2: 3PH 0-U1 0-600Hz
Heavy Duty: 9.4A Normal Duty: 10.5A



01182164111706023001 201

SINEE SHENZHEN SINEE ELECTRIC CO., LTD
MADE IN CHINA

MODEL: A90-4T9R4B
S/N:01182164111706023001 201

- Model Numbering Description**

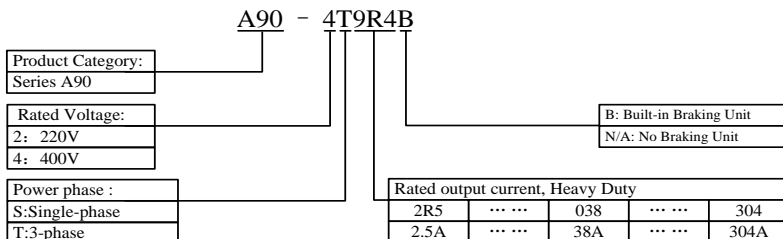

2.2 Overall and Installation Dimensions

A90 inverters can be categorized into 23 models for 2 overall appearances and 10 installation dimensions (as shown in Figure 2-1 and Table 2-2).

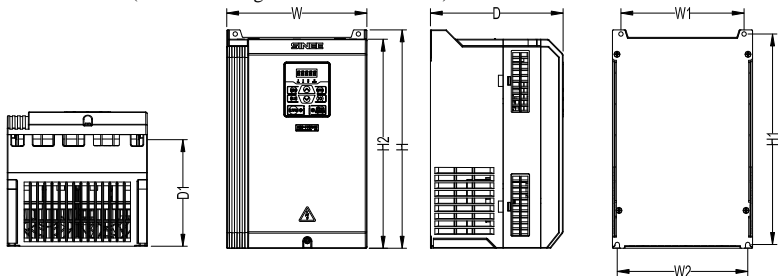

(a) Overall Dimensions of A90-4T1R5B~A90-4T045B

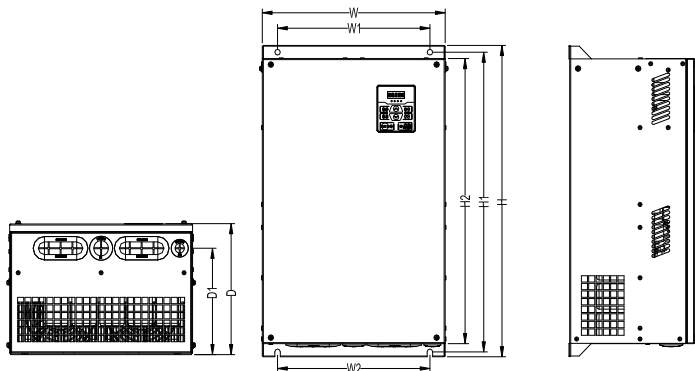

(b) Overall Dimensions of A90-4T060~A90-4T304

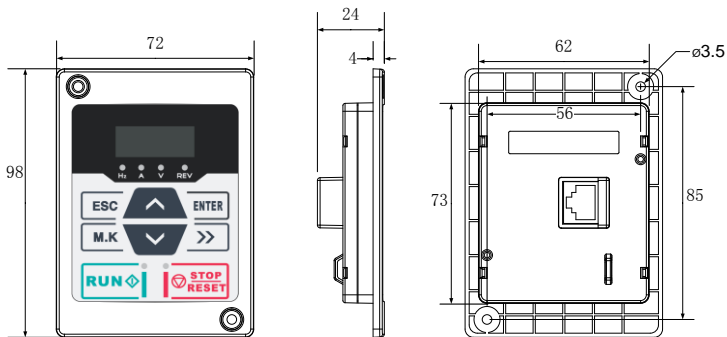

(c) Dimensions of the detachable keypad (Option)

Figure 2-1 A90 Series inverter and keypad dimensions

Table 2-1 A90 Series inverter dimensions and installation dimensions

Specifications	W	W1/W2	H	H1	H2	D	D1
A90-2S2R8B	Developing						
A90-2S4R8B							
A90-2S008B							
A90-2S010B							
A90-4T1R5B	75	65	162	153	142	103	29
A90-4T2R5B	75	65	142	133	142	141	67
A90-4T4R2B							
A90-4T5R6B	92	76/81	171	162	162	132	82
A90-4T9R4B							
A90-4T013B	109	94	218	208	207	153	102
A90-4T017B							
A90-4T025B	130	107/119	261	250	250	163	128
A90-4T032B							
A90-4T038B	190	167	293	282	280	180	143
A90-4T045B							
A90-4T060	245	210	425	410	390	188	137
A90-4T075							
A90-4T090	300	266	491	473	450	206	168
A90-4T110							
A90-4T150	335	286	491	471	450	206	170
A90-4T176	335	286	623	601	570	293	248
A90-4T210							
A90-4T253	Developing						
A90-4T304							

2.3 Requirements of the mechanical installation

2.3.1 Installation Site

The installation site shall have the following conditions:

1. Well-ventilated indoor place.
2. Ambient temperature: -10°C $-+50^{\circ}\text{C}$.
3. Avoid high temperature and high moisture, humidity $< 95\%\text{RH}$, no water drops or any other condensation.
4. Do not install inverter onto wood or other flammable materials.
5. No direct sunlight.
6. No flammable, corrosive gases and liquids, oily gases, conductive dust, salt spray, floating fibers, condensation and so on.
7. the installation of a solid foundation without vibration.
8. No obvious electromagnetic interference and away from interference source.

2.3.2 Precautions

Please take precautions during installation to prevent metal fragments or dusts produced by drilling or other actions from falling into inverter. Remove precaution objects after installation.

2.4 Installation Direction and Space

Inverter must be installed in vertical direction with enough space maintained to an adjacent object or a baffle (wall) for better cooling effect (see Figure 2-2). A90-4T4R2B and above models are equipped with cooling fans to force air cooling.

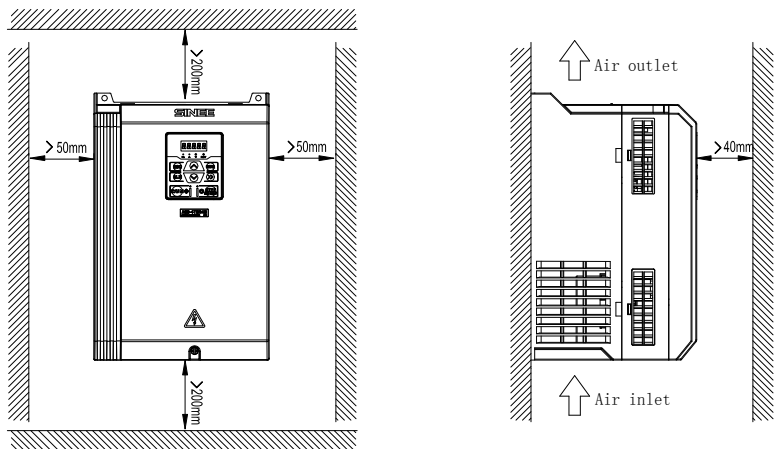

Figure 2-2 Inverter Installation Direction and Space

3 Wiring

3.1 Connection to Peripherals

Standard connection between A90 and peripherals is shown in Figure 3-1.

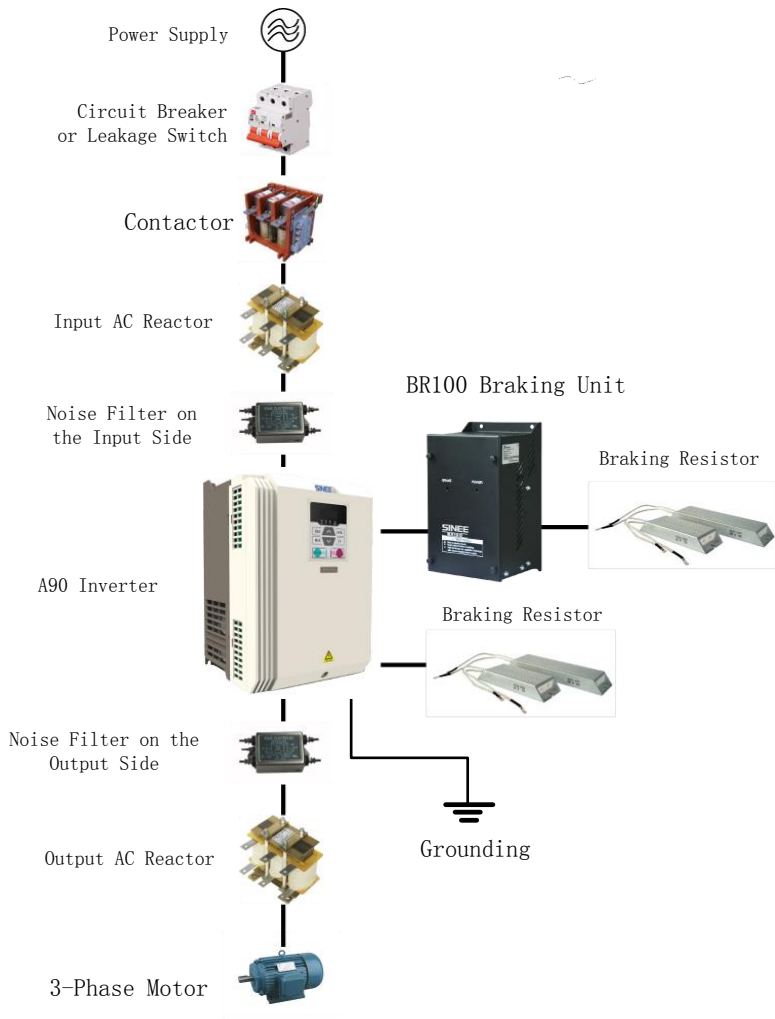
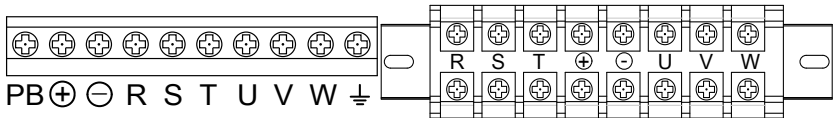

Figure 3-1 Connection of A90 Inverter and Peripherals

3.2 Power terminal connections

3.2.1 Examples of the power terminal



- a) small and medium power terminal, part of the terminals slightly different
- b) high-power terminal diagram, part of the terminals slightly different

Figure 3-2 Power Terminal Block

3.2.2 Power Terminal Functions

Please correctly wire terminals according to functions.

Terminal No.	Function Description
R, S and T	AC power supply input terminals, to connect to 3-phase AC power supply.No phase sequence requirement.
U, V and W	AC output terminals , to connect to 3-phase AC motor. Consider the phase sequence requirement.
⊕ ⊖	Positive and negative terminals of internal DC bus, to be connected to the external brake unit.
⊕ and P	DC reactor connection terminals, only used of A90-4T176 and above models.
⊕ and PB	Brake resistor connection terminals, one end connected to ⊕ and the other end to PB.
⊕	Grounding terminal.

3.2.3 Standard Wiring of Power Terminal

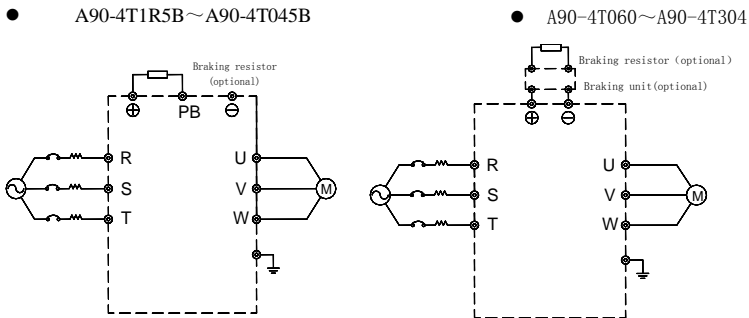

Figure 3-3 Standard Wiring of Power Terminal

3.2.4 Wiring on Input Side of Power terminal

3.2.4.1 Interference precaution

Please refer to Figure 3-1 for the inverter peripherals, install the EMI filter and inverter on the same iron plate, and shield the inverter and the peripheral parts with the iron box. Can reduce interference to outside. The wiring requirements are shown in Figure 3-4. For more details to reduce external interference, refer to the A90 User's Guide.

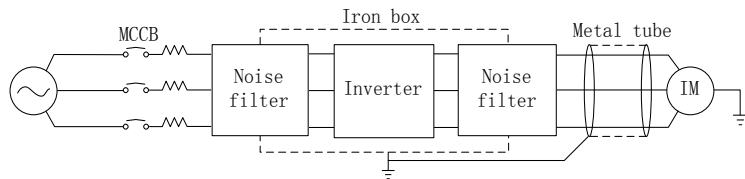

Figure 3-3 Measures to reduce external interference

3.2.5 Cable and screw size

Cable size and terminal screw specifications, refer to A90 Inverter User's Guide.

3.2.6 Brake resistor and brake unit installation wiring

If you need quickly stop or frequently stop, brake resistor and brake unit selection method see Chapter 8.

For models with built-in brake units, the brake resistor is connected between the inverter + and the PB terminals. For inverters without built-in brake units, connect the +, - terminals of the brake unit to the DC bus bar +, - terminals of the inverter and connect the brake resistor to the PB + and PB- terminals of the brake unit on. For more information, refer to the BR100 Brake Unit User Guide.

3.3 Control Terminal connections

3.3.1 Control Terminals

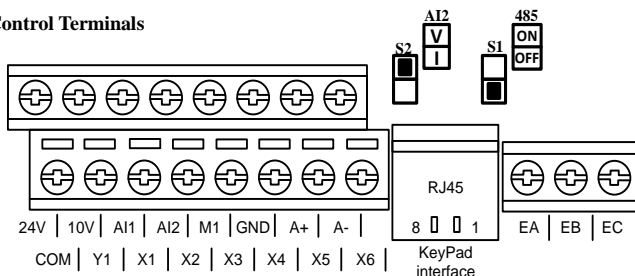

Figure 3-4 Control Terminal Block

3.3.2 Function and Wiring of Control Terminals

Table 3-2 Control Terminal Functions

Mode	Terminals	Function	Detailed description
Auxiliary Power Supply	10V-GND	+10V Power Supply	Offers a +10V power supply, maximum output current: 10mA.
	24V-COM (A90-4T017B and the smaller models are 24V-GND)	+24V Power Supply	Offers +24V power supply, generally used as a working power supply for digital input or output terminal, or external device power supply. Maximum output current: 100mA.
Analog Input	AI1-GND	Analog Input Terminal 1	Input voltage range: DC 0 - 10 V Input impedance: 1MΩ
	AI2-GND	Analog Input Terminal 2	Input range: DC 0-10 V or 0-20 mA; select the voltage/ current mode by switch S2 on the Control board. Input impedance: Voltage mode 1 MΩ, current mode 250 Ω
Digital Input	X1-COM(*)	Digital Input1	Optocoupler isolated input terminals, Common for COM Functions selected by F02.00-F02.05 Input impedance: 5.1 kΩ (* A90-4T017B and the smaller models without optocoupler isolation, the common is GND)
	X2-COM(*)	Digital Input2	
	X3-COM(*)	Digital Input3	
	X4-COM(*)	Digital Input4	
	X5-COM(*)	Digital Input5	
	X6-COM(*)	Digital Input6	
Analog Output	M1-GND	Analog Output Terminal	Output range: DC 0 - 10 V. Functions selected by F03.21
Digital Output	Y1-COM(*)	OC Output Terminal	Optocoupler isolated, Open-Collector output. Maximum output voltage: DC 24V Output current: 50 mA Functions selected by F03.00 (A90-4T017B and the samller models is Y1-GND)
Relay Output	R1: EA-EB-EC	Relay Output Terminal	EA-EC:Normally Open EB-EC:Normally Close Functions selected by F03.01
Communication	A+	RS-485	RS485 communication (+)
	A-	Communication Interface	RS485 communication (-)

3.3.3 Analog Input Terminal Wiring

3.3.3.1 Wiring Terminals AI1 and AI2 with Analog Voltage Signal:

When analog voltage input signal is powered by external power supply, terminals AI1 and AI2 are wired as Figure 3-6-a.

When analog voltage input signal is generated by potentiometer, terminals AI1 and AI2 are wired as Figure 3-6-b.

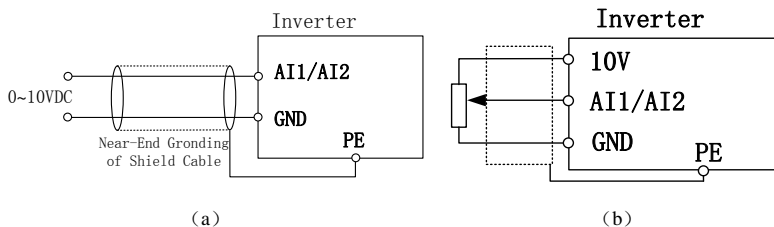

Figure 3-6 Wiring of Terminals AI1 and AI2

3.3.3.2 Wiring of Terminals AI2 with Current Signal:

When analog current signal input on terminals AI2, configure current mode through switches S2 on the control board.

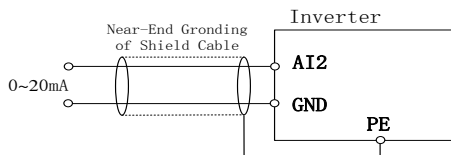

Figure 3-5 External power supply current source and AI2 terminal wiring diagram

3.3.4 Wiring of the Digital Input Terminal

For A90 inverter, the common terminal of the digital terminals is the COM (A90-4T017B and the smaller models is GND). Shorted digital input terminal to COM is Enable, and disconnected is Disabled (NPN mode). The typical wiring is shown in Figure 3-10.

3.3.5 Digital output terminal wiring

The Digital output terminal Y1 can be powered by 24V inside the inverter or an external 24V power supply, as shown in Figure 3-8:

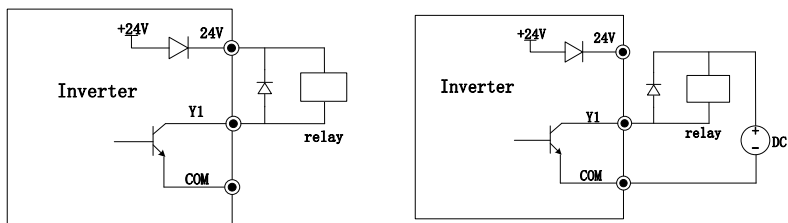

a: Use internal power supply

b: Use an external power supply

Figure 3-6 Digital output terminal wiring

Note: The relay coil must be added to the anti-parallel diode. The elements of the absorption circuit are to be mounted on both ends of the coil of the relay or contactor.

3.3.6 Analog Output Terminal Wiring

Analog output terminal M1 can represent a variety of physical quantities. M1 Output voltage (0 ~10V).

3.3.7 Wiring of 485 Communication Terminal

Communication terminals A+ and A- are RS485 communication interfaces. Connect A+ to the controller's communication positive terminal, A- to the controller's communication negative. To achieve the host computer (PC or PLC controller) and the inverter network control. RS485 and A90 series inverter connection shown in Figure 3 9. Turn the last inverter's S1 ON.

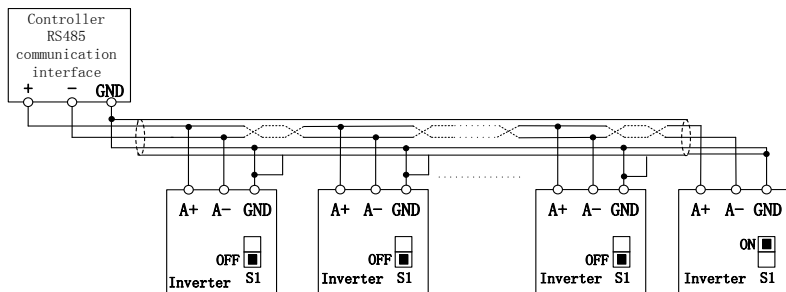

Figure 3-9 multi-inverter/single inverter communication terminal wiring

3.3.8 Standard Wiring of Control terminal

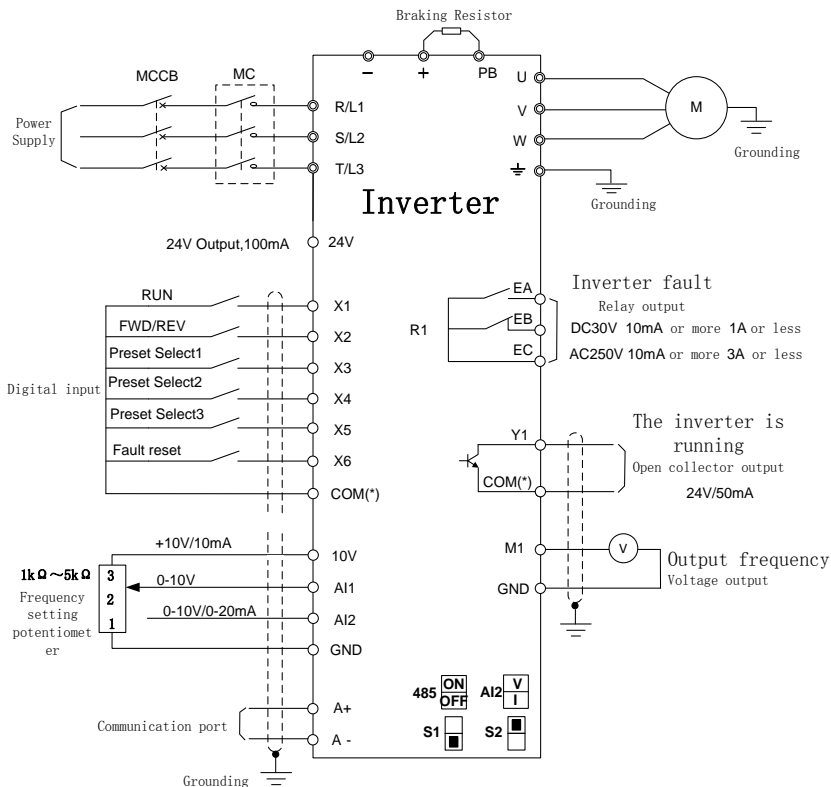

Figure 3-10 Standard Wiring of Control Circuit

A90-4T017B and the smaller models, the common terminal is GND

3.4 Detachable keypad wiring

- 1) Detachable keypad is an Option, need to be ordered separately.
- 2) Detachable keypad with RJ45 interface, can work with the ordinary network cable (EIA / TIA568B standard). Manufacturer does not provide the network cable.
- 3) Connect the RJ45 port on the keypad and the RJ45 port on the control board.
- 4) The cable less than 3m is recommended. In a good electromagnetic environment and with a high quality network cable, the length can be up to 10 meters.

4 Keypad and display

4.1 Keypad Function

4.1.1 LED Keypad







A90 inverter's control panel is a fixed LED keypad. LED keypad has five digital displays, eight operation keys, six status and unit indicators. The keypad and display are used for Displaying the operating status of the inverter; Displaying a fault or trip code; Reading and changing parameter values; Stopping, starting and resetting the inverter.









Figure 4-1 LED keypad

4.1.2 Functions of keys and Indicators

Table 4-1 Functions of keys and Indicators

Key/Indicator	Name	Function
	Right Shift	Select the group number and the parameter; Switch monitoring parameters
	Escape	Back to previous menu; Escape from editing present parameter; Switch between menu mode and monitoring mode.
	Multi-Functional Programmable Key	Default is JOG forward. Can be set for other functions through parameter F12.00.
	Enter	Enter the next menu. Confirm and save parameter modification and enter the next parameter.
	Run	To start inverter if keypad control is valid.
	Stop/Reset	To stop inverter if keypad control is valid. In fault status, reset the trip code if the fault can be reset.

	Up key	Increase the parameter number, group number, or parameter value. Increase the current digital input reference frequency.
	Down key	Decrease the parameter number, group number, or parameter value. Decrease the current digital input reference frequency.
	Unit indicator	The light is ON when the current display parameters for the frequency, current, voltage type.
	Running direction indicator	The light is ON when running Reverse; The light is OFF when running Forward; The light is ON when current display frequency is negative.
 (green)	Running lights	The light is ON when the inverter is running; The light is flashing when the inverter is ramp to stop; The light is OFF when the inverter is Stopped;
 (red)	Fault indicator	The red light is ON when the inverter is in fault condition.

4.2 Keypad operation mode

The LED keypad menu is divided into the monitor level (level 0), the menu mode selection level (level 1), the parameter selection level (level 2), the parameter value level (level 3). The guide will use the level number to narrate.

The level 1 has 5 selections: All menu mode (-- A--), used to display all the parameter; User-defined mode (- -U--), used to display only the user defined parameters through the F11 group; Non-factory default mode (-- C--), used to display only Changed parameters, compare with the factory default; Fault information display mode (-- F--), used to display the current fault information; version information mode (- -P--), used to display software and product serial number.

The keypad power-up display is level 0 , Press the ESC key to enter the level 1. In level 1, press UP key or Down key to select different menu modes. Menu mode selection operation flow shown in Figure 4-2

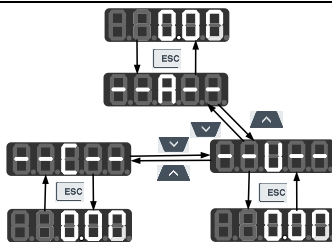

Figure 4-2 Menu Mode Selection

4.2.1 All menu mode (--A--)

Press **ENTER** under the all menu mode to enter the level 2 to select any parameter. Press **ENTER** again to enter the level 3 to review or modify parameters.

At the all menu mode, the example from power-on to change F03.28 to 5.28 is shown in Figure 4-3.

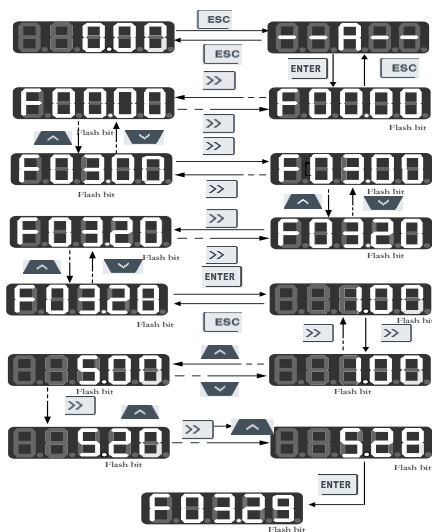

Figure 4-3 Example from Power-on to Setting F03.28=5.28

Under each menu mode, press **ENTER** to save parameter change. The difference is that after having saved the parameter: it enters the next parameter under All menu modes; it enters the next user-defined parameter (as the sequence in F11.00 - F11.31) under User-defined mode; it enters the next non-factory parameter under non-factory defaults mode.

Press **ESC** to cancel parameter change under the level 3.

5 Quick start commissioning

5.1 Commissioning process

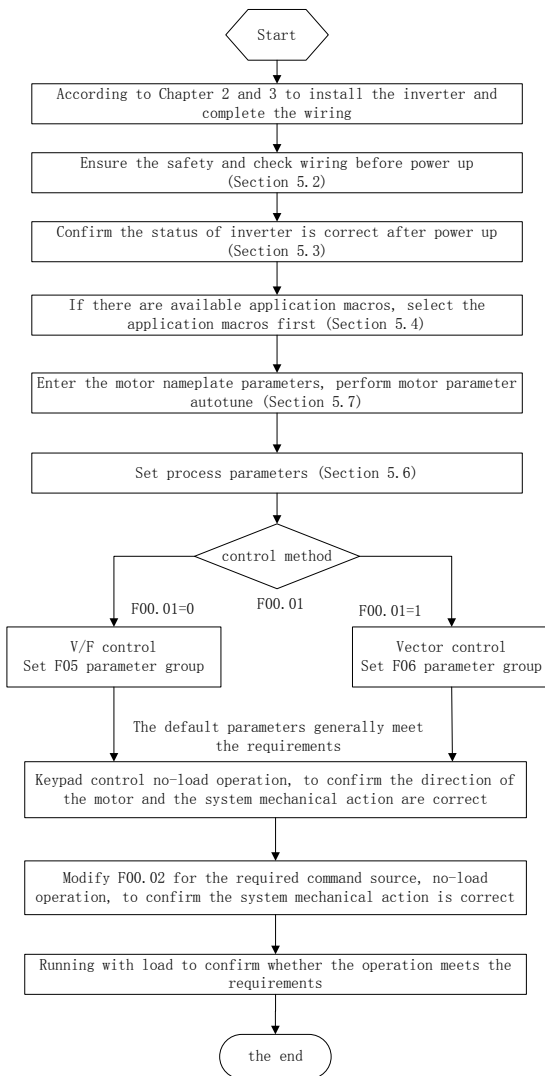

Figure 5-1 Commissioning process

5.2 Check list before power up

Be sure to confirm the following items before turning on the power:

Confirm items	Contents
Check Power supply wiring	Make sure the input supply voltage is the same as the inverter's requirements
	Make sure the power supply circuit is connected to the circuit breaker and the power cable are connected to the R, S, T terminals of the inverter
	Make sure the inverter and the motor are properly grounded
Check Motor wiring	Make sure the motor is connected to the U, V, W terminals of the inverter and the phase sequence is correct. Ensure the connection is firm.
Check Brake unit and brake resistor wiring	Make sure that the brake resistor and the brake unit are wired as shown in Figure 3-3 (if the dynamic brake is required)
Check Control terminals wiring	Check control terminals and other control devices connected correctly, reliably
Check Control terminal status	Confirm all terminals are disabled, to prevent running from power up
Check Mechanical load	Confirm the machine at no load condition and there is no danger after power up and machine running

5.3 Confirm the status of the inverter after power up

When the power is up, the inverter keypad is displayed as follows:

State	Display	Description
Normal	50.00	The factory default display is digital setting 50.00Hz
Fault	Character or Exx format trip code	When trip code is displayed, refer to Chapter 6 Trouble Shooting







5.4 Note about the macro

F16.00 for the industry application macro selection, according to the need to select the macro, press the Enter key to confirm. You need to select F12.14 = 1 to restore the factory value, **Then** the application macro is available. See Chapter 10 for details on application macros.

5.5 Start and stop control

No.	Function	Range	Default	Type
F00.02	Command Source	0: Keypad Control 1: Terminal Control 2: Communication Control	0	○

F00.02=0: Keypad Control

The start and stop of inverter will be controlled with ,  and  of keypad. Under no fault, press  to enter jog forward or press  to enter running mode. When the green LED above the  button is on, it means that inverter is running; when the green LED above the  button flickers, it means that inverter is in the ramp-to-stop status.

F00.02=1: Terminal Control

The start/stop control terminal defined through F02.00 - F02.05 controls the start and stop of inverter; the detailed configurations of the terminal control are defined through F00.03.

F00.02=2: Communication Control

The host controller controls inverter to start and stop through RS485 communication interface. See SINEE inverter 's communication protocol for detail.

No.	Function	Range	Default	Type
F04.00	Start Mode	0: Start Directly 1: Speed Tracking Start	0	○

F04.00=0: Start Directly

Inverter starts with DC brake (not available if F04.04=0), then conducts the pre-excitation (not available if F04.07=0), then starts at the start frequency, and enters the set frequency running after the retention time of the start frequency.

F04.00=1: Speed Tracking Start

Inverter will first perform the rotation speed tracking (speed and direction) at startup, and start up smoothly from the actual rotation frequency of motor

No.	Function	Range	Default	Type
F04.19	Stop Mode	0: Ramp-To-Stop 1: Coast-to-Stop	0	○

F04.19=0: Ramp-To-Stop

Motor ramps to stop after the set deceleration time is out [default setting is as per F00.15 (deceleration time 1)]

F04.19=1: Coast-to-Stop

After enabling the stop command, inverter will stop output immediately and motor will coast to stop. Specific stop time depends upon the inertia of motor and the load.

If the coast-to-stop terminal is set, inverter coasts to stop immediately after the coast-to-stop terminal is enabled; inverter will not run again even if the terminal is disabled unless a run command is inputted.

5.5.1 Terminal control starts and stops

No.	Function	Range	Default	Type
F00.03	Terminal Control Mode Options	0: Terminal RUN for running, Forward/Reverse (F/R) 1: Terminal RUN for forward, F/R for reverse 2: Terminal RUN for forward, Xi stop, F/R reverse 3: Terminal RUN for running, Xi stop, Forward/Reverse (F/R)	0	○

Terminal RUN: Xi=1(set by F02.00-F02.05,default X1 is terminal RUN)

Terminal F/R: Xi=2, (set by F02.00-F02.05,default X2 is terminal F/R)

There are two kinds of terminal control modes, 2-wire sequence and 3-wire sequence.

2-Wire Sequence:**F00.03=0: Terminal RUN for running, Forward/Reverse by terminal F/R**

ON/OFF of terminal RUN controls the start and stop of inverter and OFF/ON of terminal F/R controls the forward/reverse of inverter; if F00.21 is set as 1 (reverse is prohibited), terminal F/R is disabled. By selecting the ramp-to-stop for the stop mode, the logic diagram is shown in Figure 5-2 (b).

F00.03=1: Terminal RUN for forward running , Terminal F/R for reverse running

ON/OFF of terminal RUN controls the forward running and stop of inverter and ON/OFF of terminal F/R controls the reverse and stop of inverter. If terminals RUN and F/R are on, inverter stops. If reverse is prohibited, terminal F/R is disabled. When selecting the ramp-to-stop, the control logic of inverter Forward/Reverse is shown in Figure 5-2 (d);

Figure 5-2 (d);

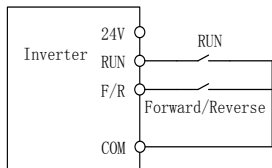

(a) F00.03 = 0 2-wire sequence wiring diagram

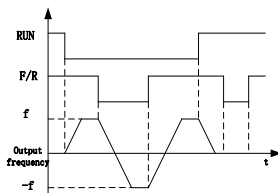

(b) F04.19=0, F00.03=0 Running sequence

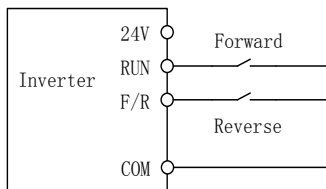

(c) F00.03=1 2-wire sequence wiring diagram sequence

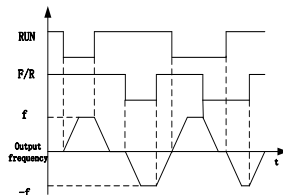

(d) F04.19=0, F00.03=1 Running sequence

Figure 5-2 2-wire sequence



When selecting F00.03 start/stop option as 0 or 1, if pressing  or using an external terminal stop command to stop inverter, even if terminal RUN is on, the inverter will not run again. At this condition, terminal RUN should be disabled and then enabled, it can once again enter running state.

3-Wire Sequence:

F00.03=2: Terminal RUN for forward, Xi for stop, F/R for reverse

RUN is a Normally Open forward running button and F/R is a NO reverse running button too; both of them are effective at pulse edge; Xi is a Normally Close stop button and enabled at the level. Under running mode, pressing Xi can stop inverter. When stop mode is set as F04.19=0 Ramp-To-Stop, the logic diagram is shown in Figure 5-3 (b). Xi is a terminal among X1 – X6 and defined as 3-Wire Sequence Run/Stop Control.

F00.03=3: Terminal RUN for run, Xi for stop, F/R for direction

RUN is a Normally Open running button, and will be on at pulse edge (F/R is enable at level). F/R is a forward/reverse switch (inverter forward running when F/R is disabled, and inverter reverses when F/R is enabled). Xi is a Normally Close stop button, and enable at the level. When the stop mode is set as F04.19=0 Ramp-To-Stop, the logic sequence is shown in Figure 5-3 (d).

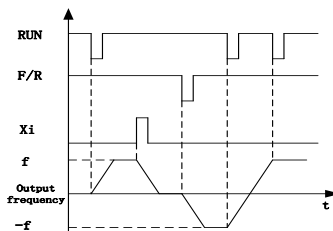
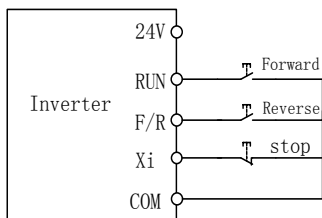

(a) F00.03=2 3- wire sequence wiring diagram (b) F04.19=0, F00.03=2 Running sequence

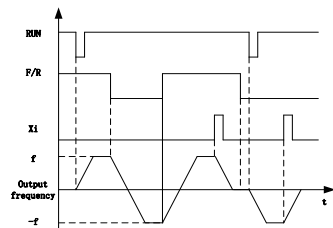
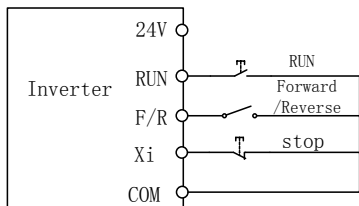

(c) F00.03=3 3- wire sequence wiring diagram (d) F04.19=0, F00.03=3 Running sequence

Figure 5-3 3-wire sequence



The 3-wire sequence of A90 inverter conforms to traditional electrical control method. Please use buttons and switches as shown in the diagram correctly so as to avoid malfunctions.

5.6 Frequently used process parameters

No.	Function	Range	Unit	Default	Type
F00.01	Drive Control Mode of Motor 1	0: V/F control (VVF) 1: Sensorless Vector Control (SVC)		0	○
F00.04	Main Frequency Source A Options	0: Digital Frequency Setting F00.07 1: AI1 2: AI2 6: Main Frequency Communication Percentage Setting 7: Main Frequency Communication Direct Setting		0	○
F00.07	Digital Frequency Setting	0.00 Hz - Maximum Frequency F00.16	Hz	50.00	●
F00.14	Acceleration Time 1	0.00~650.00 (F15.13=0)	s	15.00	●
F00.15	Deceleration Time 1	0.00~650.00 (F15.13=0)	s	15.00	●
F00.16	Maximum Frequency	1.00~600.00	Hz	50.00	○
F00.18	Upper Limit Frequency	Lower Limit Frequency F00.19 - Maximum Frequency F00.16	Hz	50.00	●
F00.19	Lower Limit Frequency	0.00 - Upper Limit Frequency F00.18	Hz	0.00	●

F00.21	Reverse Control	0: Permit Forward/Reverse 1: Prohibit Reverse		0	○
--------	-----------------	--	--	---	---

Note: Commonly used process parameters may also include input and output terminal function settings, please refer to the function table F02 group and F03 group .

5.7 Motor parameter autotune

For better control performance, motor parameter autotune is required.





Autotune selection	Conditon	Effect
F01.34=1 Asynchronous motor Stationary autotune	Stationary autotune is applied to the occasions when motor can not be disconnected from load.	Good
F01.34=11 Synchronous motor Stationary autotune		
F01.34=2 Asynchronous motor rotational autotune	Rotational autotune is applied to the occasions when motor can be disconnected from load. Before autotune, motor should be disconnected from load. Never perform rotational autotune for a motor with load.	Better
F01.34=12 Synchronous motor rotational autotune		

- Make sure that motor is in stop status before autotune, otherwise, autotune can not be performed normally.

5.7.1 Steps of Autotune

- If the motor can be disconnected from load, disconnect motor from load under power off status.
- Power on, select command source as Keypad Control (set F00.02=0)
- Set motor parameters according to the nameplate correctly

Motor	Corresponding parameters
Motor 1	F01.00 Motor type F01.01: Motor rated power F01.02: Motor rated voltage F01.03 Motor rated current F01.04: Motor rated frequency F01.05: Motor rated speed F01.06: Motor wiring method
Motor 2	F14.00-F14.06: With the same meaning as above, if need motor 2

- For asynchronous induction motor
By setting F01.34=1, then pressing , inverter starts stationary autotune for motor. Or by setting F01.34=2, then pressing , inverter starts rotational autotune for motor.
- For permanent-magnet synchronous motor
By setting F01.34=11, then pressing , inverter starts stationary autotune for motor. Or by setting F01.34=12, then pressing , inverter starts rotational autotune
- It takes about 2 minutes to complete the autotune and, afterwards, keypad returns from TUNE to the initial power-on status.
- If autotune fails, inverter will display “E24” parameter autotune abnormality. By pressing RESET key, inverter will return to parameter setting status
- If more than one motor in parallel, input sum of the motor power and sum of the current;
- If two motors are switched, set the F14 group for motor 2 and do autotune.

6 Troubleshooting

6.1 Faults

When something abnormal happens to inverter, keypad will display corresponding fault code and parameter; the fault relay is on, the fault output terminal is on, inverter output stops. If motor is still running when a fault occurs, it will stop by the setting mode. For A90 faults and troubleshooting, see Table 6-1.

Table 6-1 A90 Faults and Troubleshooting

Fault Code	Fault type	Cause	Troubleshooting
<i>E01</i>	Short Circuit/ electromagnetic interference	1. Short circuit between output phase and ground 2. Short circuit between output phases 3. Short circuit of brake resistor 4. Acceleration/deceleration time is too short 5. Power module is damaged 6. Electromagnetic interference	1. Check if there is any short circuit phenomenon. 2. Extend acceleration/ deceleration time 3. Investigate causes and reset inverter after taking appropriate measures. 4. Seek for technical support.
<i>E02</i>	Instantaneous Overcurrent	1. Acceleration/deceleration time is too short. 2. Under V/F control mode, V/F curve has been set irrationally. 3. Motor is running when inverter starts. 4. Motor exceeds inverter capacity or load is too heavy. 5. The motor parameters aren't correct 6. Short circuit between inverter output phases 7. The inverter is damaged	1. Extend acceleration/ deceleration time. 2. Set V/F curve rationally. 3. Enable the track start or start DC brake. 4. Replace with an appropriate motor or inverter. 5. Perform motor autotune. 6. Check if there is any short circuit phenomenon in wiring. 7. Seek for technical support.
<i>E03</i>	Instantaneous Overvoltage	1. Deceleration time is too short and regenerated energy is too large. 2. Brake unit or brake resistor does not work. 3. The brake unit or brake resistor does not match. 4. Power supply voltage is too high. 5. The function of dynamic braking is not enabled	1. Extend deceleration time. 2. Check the brake unit and brake resistor wiring, and enable F15.30 for built-in models. 3. With the appropriate brake unit / brake resistor. 4. Reduce the power supply voltage down to a specified range.
<i>E04</i>	Stable Overcurrent	Refer to E02	Refer to E02
<i>E05</i>	Stable Overvoltage	Refer to E03	Refer to E03
<i>E06</i>	Undervoltage	1. Input voltage phase loss. 2. Wiring terminals of input are	1. Check the input voltage and wiring.

		loose. 3.Input voltage drops too much. 4.Aging of switch contact on input power supply.	2.Tighten screws of input wiring terminal. 3.Check air switch and contactor.
<i>E07</i>	Input Phase Loss	1.Input voltage phase loss. 2.The input power fluctuates greatly	1.Check input voltage. 2.Check input voltage wiring. 3.Check whether the connection terminals are loosened.
<i>E08</i>	Output Phase Loss	1. Phase loss of U, V or W	1.Check the connection between inverter and motor. 2.Check whether motor winding is disconnected; 3.Check whether output terminals are loosened.
<i>E09</i>	Inverter Overload	1. Acceleration/deceleration time is too short. 2. Under V/F control mode, V/F curve has been set irrationally. 3. Load is too heavy. 4. Brake time is too long; Repeated DC brake	1.Extend acceleration/deceleration time. 2.Set VF curve rationally. 3.Replace inverter that matches with the load. 4.Reduce brake time; Do not repeatedly DC brake
<i>E10</i>	Inverter Overheat	1. Ambient temperature is too high. 2. Inverter is in poor ventilation. 3. Cooling fan fault.	1. Running conditions shall comply with specification requirements. 2. Improve ventilation environment and check whether heatsink is blocked. 3. Replace the cooling fan.
<i>E11</i>	Parameter Setting Conflict	1. Parameter setting logic conflict	1. Check whether parameters set is unreasonable.
<i>E13</i>	Motor Overload	1. Acceleration/deceleration time is too short. 2. Under V/F control mode, V/F curve has been set irrationally. 3. Load is too heavy.	1. Extend acceleration/deceleration time. 2. Set VF curve rationally. 3. Replace motor with another one that matches with the load.
<i>E14</i>	External Fault	1.Peripheral fault terminal is enabled.	1.Check peripherals.
<i>E15</i>	EEPROM Fault	1.Interference results in reading and writing errors of EEPROM. 2.The controller repeatedly writes the internal memory, causing the memory to be damaged.	1.Press STOP/RESET to reset and then try it again. 2. Do not repeatedly writes the internal memory. 3. Set F10.56=11 to avoid damage
<i>E16</i>	Communication Abnormality	1.the communication time out is enabled for discontinuous communication system	1.Set F10.03 = 0.0 for discontinuous communication system

		2.communication cable disconnected	2.Check whether the communication cable is disconnected. 3.Adjust the communication overtime (F10.03).
<i>E 17</i>	Inverter Temperature Sensor Abnormality	1. Temperature sensor of inverter is off or short-circuited.	1.Seek for technical support
<i>E 18</i>	Soft Start Relay Off	1. Power off at running status. 2. Input voltage phase loss. 3. Wiring terminals of input voltage are loosened. 4. Input voltage drops too much. 5. Aging of switch contact on input power supply.	1. Shut down power supply after the inverter stopped 2. Check the input voltage and check power terminals wiring. 3. Tighten screws of input wiring terminal. 4. Check air switch and contactor.
<i>E 19</i>	Current Detection Circuit Abnormality	1. Detection circuit of drive board or control board is damaged.	1. Seek for technical support.
<i>E20</i>	Stall Fault	1.The set deceleration time is short. 2. Dynamic brake abnormality at ramp-to-stop. 3. The load is too heavy.	1.Extended deceleration time. 2.Check the brake resistor and brake unit and wiring. 3.Check whether the motor is driven by another load can not stop.
<i>E21</i>	PID Feedback Disconnection	1. PID feedback is higher than upper limit F09.24 or lower than lower limit F09.25, depending upon types of sensors.	1. Check whether the feedback line falls off; 2. Check whether the sensor works abnormally; 3. Adjust the feedback disconnection detection value to a reasonable level.
<i>E24</i>	Autotune Abnormality	1. Press STOP/RESET in the parameter autotune. 2. In autotune, the external coast-to-stop terminal FRS=ON. 3. Motor is not connected to output terminal of inverter. 4. Motor is not disconnected from load for rotational autotune. 5. Motor fault.	1. Press STOP/RESET to reset. 2. Check the connection between inverter and motor. 3. Motor is disconnected from load for rotational autotune. 4. Check motor.
<i>E26</i>	Offload Protection	1.The motor is not connected, or the motor does not match. 2.Appeared off the overload	1.check the wiring, replace the matching motor 2.check the equipment

		condition 3.Load loss protection parameter setting unreasonable.	3.Change the load detection level F07.22 and the detection time F07.23.
E27	Accumulated Power-On Time is up	The time of maintenance of the inverter is up	Please contact your dealer for technical support.
E28	Accumulated Running time is up	The time of maintenance of the inverter is up	Please contact your dealer for technical support.
E57	Pipe overpressure	The feedback pressure is too high for water supply applications.	1. Check if the sensor is abnormal. 2. Check whether the analog terminal can detect the analog input normally. 3. Check the external device.

When fault occurs, Press the STOP / RESET key to reset or enable the fault reset terminal to exit the fault state. if the fault has been eliminated, the inverter returns to the function setting state; if the fault has not been eliminated, the LED will continue to display the current fault code.





If you can not solve the problem after handling the fault, please contact your dealer or company service personnel.

When using the communication read fault code, the number corresponding to the fault number is "E" after the letter, and the number corresponding to "E01" is "01".

6.2 Failure analysis

After power is on, due to improper function setting and incorrect wiring between inverter and external control terminals, motor cannot meet the expected working requirements. Fault analysis as described in this chapter can be taken as the reference to take the corrective actions. If trip codes appear, refer to 6.1 Troubleshooting.

6.2.1 The parameter parameter can not be set

- Press the up  or down  key to not change the parameter
When the inverter is running, some parameters are not allowed to be modified and must stop to be modified.
- Press the Up key  or Down key , the parameter display is variable, but the memory is invalid.

Some features of the code parameter set to a locked state, can not be modified.

When F12.02 is selected as 1 or 2, the limit parameter change will occur. Set F12.02 to 0. Or set the user password, there will be parameters can not be modified.

6.2.2 Abnormal Motor Operation

- After pressing , motor does not run.
 - Start/Stop is in the terminal control mode: Check the setting of F00.02.
 - Coast-to-stop terminals is connected to COM: Disconnect Coast-to-stop terminals from COM.
 - When the terminal (Run Command Switched to Terminal) is on and run command is only in terminal control mode: Switch the terminal off.

- Status combination of run command input is in terminal control mode: Change it to keypad control mode.
- Setting reference input frequency= 0: Increase reference input frequency.
- Power supply is abnormal or control circuit fails.
- When control terminals RUN and F/R are ON, motor does not run.
- Command channel is not terminal control: Check function setting code F00.02 Command channel setting.
- Free stop terminal and COM closed: Disconnect the free stop terminal from COM.
- control switch failure: check the control switch and the relevant wiring is correct, whether there is a broken line exists
- Reference input frequency is set to 0: Increase the reference input frequency.
- The digital input terminal is selected for the inverter to enable the terminal to be inactive: Closed to enable the terminal.
- The motor can only rotate in one direction
Reverse rotation is disabled: When the reverse inhibit code parameter F00.21 is set to 1, the motor is not allowed to reverse.
- The motor rotates in the opposite direction
Inverter output phase sequence and the motor input is not consistent: 10 minutes in the power off, and the motor stationary state, any exchange of two motor connections can change the direction of rotation of the motor.

6.2.3 Motor acceleration time is too long

- Set the acceleration time too long: Please confirm the acceleration time code parameter。
- Too heavy load: Make sure the load is jammed, or if the motor does not match the load.
- Before running the motor is rotating: Please use the start DC brake, or the speed tracking start.

6.2.4 The motor deceleration time is too long

- When the energy consumption brake is active
 - Brake resistor resistance is too large, energy consumption Brake power is too small to extend the deceleration time: Please press the guide to select the appropriate brake resistor.
 - Set the deceleration time too long: Please confirm the deceleration time code parameter.
 - Built-in brake unit of the inverter, not activated Power consumption Brake function: Check whether F15.30 is a 1 energy brake effective.
- When stall protection is active
 - Overvoltage stall protection operation, the DC bus voltage exceeds the overvoltage stall voltage (F07.07),The output frequency remains unchanged,When the DC bus voltage is lower than F07.07,
The output frequency continues to decline,This extends the deceleration time.
 - The set deceleration time is too long. Please confirm the deceleration time code parameter.

6.2.5 Electromagnetic interference and radio frequency interference

- When the inverter is running, because the inverter work in the high-frequency switching state, the control equipment will produce Electromagnetic interference and RF interference, the following measures can be taken:

- Reduce the carrier frequency of the frequency converter (F00.23).
- Set the noise filter on the input side of the drive.
- Set the noise filter on the output side of the frequency converter.
- The outer cover of the metal is attached to the metal tube. The frequency converter is installed in the metal case
- The inverter and the motor must be reliably grounded.
- The main circuit is connected and the control circuit is connected separately. The control circuit uses a shielded wire and connects the shielded wire as shown in Chapter 3 Wiring.

6.2.6 Leakage circuit breaker action

- When the inverter is running, the leakage circuit breaker operates
As the output of the inverter is a high-frequency PWM signal, it will produce high-frequency leakage current, please use the current sensitivity of more than 30mA inverter leakage circuit breakers; If the ordinary leakage circuit breaker, please use the current sensitivity of 200mA or more, The action time is 0.1 seconds or more of the leakage circuit breaker.

6.2.7 Mechanical vibration

- The natural frequency of the mechanical system resonates with the frequency of the carrier carrier
The motor has no problem, but when the machine produces a sharp sound resonance, it is due to the natural frequency of the mechanical system resonating with the frequency of the carrier carrier. Please adjust the F00.23 carrier frequency to avoid the resonant frequency.

- The natural frequency of the mechanical system resonates with the output frequency of the frequency converter

The natural frequency of the mechanical system resonates with the output frequency of the frequency converter and generates mechanical noise. Please use the oscillation suppression function (F05.13), or set the anti-vibration rubber and other anti-vibration measures on the motor floor.

- PID control oscillation
PID controller adjustment parameters P, Ti, Td settings do not match. PID Please re-set the PID parameters.

6.2.8 The inverter stops outputting the motor and still rotate

- Poor parking brake
 - Stop DC brake torque is too small. Increase parking DC brake current set value (F04.21).
 - Stop DC brake time is too short.. Increase the DC brake stop time setting (F04.22). Under normal circumstances, please give priority to increase the parking DC brake current.

6.2.9 The output frequency is not output at a given frequency

- Given over the upper limit frequency
When the given frequency exceeds the upper limit frequency setting, the output frequency is output at the upper limit frequency. Reset the given frequency so that it is within the upper limit frequency range; or check if F00.16, F00.17 and F00.18 are appropriate.

6.2.10 After power on the keypad does not light or intermittent light off

- Terminal board 24V short circuit
Check whether the terminal or peripheral 24V and COM (GND) on the control board are short-circuited.

7 Maintenance and Inspection

7.1 Routine Maintenance and Inspection of inverter

Due to the use of the inverter environment, as well as the internal components of the inverter aging and other factors, may lead to a variety of inverter failure. Therefore, in the storage, the use of the inverter must be carried out on a regular basis maintenance.

- Before using inverter, user shall check if the components are broken or the screws are loose during transportation.
- While using inverter, user shall regularly clean the dust and check whether the screws are loosened.
- If inverter is left unused for a long term, user is recommended to power on inverter every half year during the storage. Every time, inverter shall be powered on for half an hour. This will prevent the electronic device from invalidation.
- The frequency converter should avoid the use of moisture, vibration, oil, salt spray, corrosive gas, conductive dust environment. If used in such an environment, it must be placed in a cabinet with protective measures or in a small room with environmental protection.

When the inverter is running normally, please confirm the following:

- Whether the motor has abnormal sound and vibration, the motor is abnormal heat.
- Whether the ambient temperature is too high.
- The output current value is normal.
- Whether the cooling fan of the inverter is operating normally.

Depending on the usage, the customer should periodically check the frequency converter to eliminate faults and safety hazards. Check, be sure to cut off the power, until the keypad LED off 10 minutes before the check. Check the contents shown in Table 7-1.

Table 7-1 Periodically check the contents

Items	Inspection content	Countermeasures
Screws of main circuit terminal and control circuit terminal.	Whether the screws are loosened.	Tighten the screws with a screwdriver.
Cooling fin PCB	Whether there is dust or foreign object.	Clean up dust and foreign objects with dry-compressed air of 4-6kg/cm ² pressure.

Cooling fan	Whether there is abnormal sound or vibration. Whether the accumulated running time has reached to 20,000 hours.	Replace the cooling fan.
Electrolytic Capacitor	If there are phenomena of changing color, foreign odor and blister.	Replace the electrolytic capacitor.

In order to make the inverter work for a long time, it is necessary to maintain and replace it regularly for the service life of the internal parts of the inverter. The service life of the inverter components varies depending on the environment of use and the conditions of use.

Table 7-2 Frequency changer part replacement time

Part Name	Standard years of replacement
cooling fan	2 to 3 years
Electrolytic capacitors	4 to 5 years

The conditions for the replacement of the inverter parts listed in the table above are:

Ambient temperature: 40 ° C.

Load factor: 80% or less.

Running time: 12 hours per day or less.

7.2 Warranty Instruction for Inverter

SINEE will offer the warranty service if inverter has the following conditions:

Warranty is only for inverter; the warranty service will be provided to inverter that has a fault or is damaged within 12 months during normal use; if inverter has a fault or is damaged outside the 12-month period during normal use, reasonable maintenance charge is required.

There is maintenance charge for any following damage occurred in 12 months:

- Do not operate in accordance with the instructions in this guide
- Wiring error caused the inverter damage;
- Self-disassemble caused the inverter damage;
- Due to floods, fires, voltage abnormalities caused the inverter damage;

Bad environment caused damage to the inverter, especially the inverter used in conductive dust, salt spray, corrosive gases, condensation, oil, vibration and other severe environment caused damage, not within the warranty.

The costs of the services are calculated according to contract.

8 Options

8.1 Brake Resistor

When the stop performance does not meet customer requirements, there need external brake resistor or brake unit to release energy.

The power of the brake resistor can be calculated as follows:

$$P_b \text{ (The power of braking resistor)} = P \text{ (the power of inverter)} * D \text{ (brake duty cycle)}$$

D - Brake duty cycle (estimated value)

Occasionally brake D = 5%

Normally brake D = 10%

Centrifuge machine D =20%

The table below is the A90 inverter's recommended rated power an resistance of brake resistor which is for reference only (D=10% ~ 20%). If brake duty cycle is lager the power of brake resistance should be larger.

Inverter model	Motor (kW)	Resistance (Ω)	Resistor power (W)	Cable connected to the resistor (mm ²)
A90-2S2R8B	0.4	≧ 360	≧ 200	1
A90-2S4R8B	0.75	≧ 180	≧ 400	1.5
A90-2S008B	1.5	≧ 180	≧ 400	1.5
A90-2S010B	2.2	≧ 90	≧ 800	2.5
A90-4T2R5B	0.75	≧ 360	≧ 200	1
A90-4T4R2B	1.5	≧ 180	≧ 400	1.5
A90-4T5R6B	2.2	≧ 180	≧ 400	1.5
A90-4T9R4B	4	≧ 90	≧ 800	2.5
A90-4T013B	5.5	≧ 60	≧ 1000	4
A90-4T017B	7.5	≧ 60	≧ 1000	4
A90-4T025B	11	≧ 30	≧ 2000	6
A90-4T032B	15	≧ 30	≧ 2000	6
A90-4T038B	18.5	≧ 30	≧ 2000	6
A90-4T045B	22	≧ 15	≧ 4000	6

8.2 Brake Unit

For A90 series Inverter A90-4T60 and the larger models, Need to purchase BR100 series brake unit. The brake power range is 18.5~160kW。The brake unit model is as follows:

Model No.	Use occasions	Minimum resistance (Ω)	Average brake current I_{av} (A)	Peak current I_{max} (A)	Inverter power (kW)
BR100-045	Energy consumption brake	10	45	75	18.5~45
BR100-160	Energy consumption brake	6	75	150	55~160

- ★ When BR100-160 adopts minimum resistance, if brake frequency of brake unit $D=33\%$, it can continue to work. If $D>33\%$, it needs to work intermittently, otherwise an overheat protection fault will occur.

8.2.1 Cable of brake unit

All brake units, brake resistors are operating at high voltage $> 400VDC$, and in a non-continuous working condition, please select the appropriate wire.

Model No.	Average brake current I_{av} (A)	Peak current I_{max} (A)	Section of copper core cable (mm^2)
BR100-045	45	75	10
BR100-160	75	150	16

Flexible cable has better flexibility. Since cable may contact high-temperature device during use, it's better to use copper core or heat-proof flexible cable or fire-retardant cable. Brake unit and inverter should be as close as possible to each other, and it's better to keep their distance no more than 2 m, otherwise DC side cable should be twisted and sheathed with magnetic ring to reduce radiation and inductance.

8.3 Detachable keypad options

Detachable keypad is an option, please contact your agent or company marketing department.

9 Parameter List

9.1 Introduction to parameter list

A90 series inverter parameter have 20 groups of parameters . F18 group is the monitoring parameter group, used to view the inverter status; F19 group for the fault/trip record group, used to view the details of the recent 3 trips.

F00	Basic Function Parameter Group	F01	Motor 1 Parameter
F02	Input Terminal Function Group	F03	Output Terminal Function Group
F04	Start/Stop Control Parameter Group	F05	V/F Control Parameter Group
F06	Vector Control Parameter Group	F07	Protection Function Setting Group
F08	Preset Speed and Simple PLC	F09	PID Function Group
F10	Communication Function Group	F11	User-Defined Parameter Group
F12	Keypad and Display Function Group	F13	Torque Control Parameter Group
F14	Motor 2 Parameter Group	F15	Auxiliary Function Group
F16	Customized Function Group	F17	Virtual I/O Function Group
F18	Monitoring Parameter Group	F19	Fault Record Group

- ★ Part of the invisible parameters is reserved, changes may cause the inverter to run is not normal. Please avoid operating such parameters.
- ★ Parameter attributes: ● parameters can be changed in any state; ○ The running status can not be changed; × Read-only parameters;

9.2 Function Parameter List

No.	Function	Range	Unit	Default	Type
F00	Basic Function Parameter Group				
F00.01	Drive Control Mode of Motor 1	0: V/F control (VVF) 1: Sensorless Vector Control (SVC)		0	○
F00.02	Command Source Options	0: Keypad Control 1: Terminal Control 2: Communication Control		0	○
F00.03	Terminal Control Mode Options	0: Terminal RUN for running, Terminal F/R for Forward/Reverse 1: Terminal RUN for forward, F/R reverse 2: Terminal RUN for forward, Xi stop, F/R reverse 3: Terminal RUN for running, Xi stop, F/R for Forward/Reverse		0	○

A90 series Inverter User Guide

F00.04	Main Frequency Source A Options	0: Digital Frequency F00.07 1: AI1 2: AI2 3-5: Not Used 6: Main Frequency Communication Percentage Setting 7: Main Frequency Communication Direct Setting		0	○
F00.05	Auxiliary Frequency Source B Options	0: Digital Frequency F00.07 1: AI1 2: AI2 3-5: Not Used 6: Auxiliary Frequency Communication Setting 7: Auxiliary Frequency Communication Direct Setting 8-9: Not Used 10: Process PID 11: Simple PLC		0	○
F00.06	Frequency Source Options	0: Main Frequency Source A 1: Auxiliary Frequency Source B 2: Main and Auxiliary Arithmetic Results 3: Switching between Main Frequency Source A and Auxiliary Frequency Source B 4: Switching between Main Frequency Source A and Main & Auxiliary Arithmetic Results 5: Switching between Auxiliary Frequency Source B and Main & Auxiliary Arithmetic Results		0	○
F00.07	Digital Frequency	0.00 Hz - Maximum Frequency F00.16	Hz	50.00	●
F00.08	Main and Auxiliary Arithmetic selection	0: Main Frequency Source A + Auxiliary Frequency Source B 1: Main Frequency Source A - Auxiliary Frequency Source B 2: The Bigger of Main A and Auxiliary B 3: The Smaller of Main A and Auxiliary B		0	○
F00.09	Reference Option for Auxiliary Frequency Source B at Main and Auxiliary Arithmetic	0: Relative to Maximum Frequency 1: Relative to Main Frequency Source A		0	○
F00.10	Main Frequency Source Gain	0.0 - 300.0	%	100.0	●
F00.11	Auxiliary Frequency Source Gain	0.0 - 300.0	%	100.0	●

A90 series Inverter User Guide

F00.12	Synthetic Gain of Main and Auxiliary Frequency	0.0 - 300.0	%	100.0	●
F00.13	Analog Adjustment of Synthetic Frequency	0: Synthetic Frequency of Main and Auxiliary Channels 1: AI1 * Synthetic Frequency of Main and Auxiliary Channels 2: AI2 * Synthetic Frequency of Main and Auxiliary Channels		0	○
F00.14	Acceleration Time 1	0.00 - 650.00 (F15.13=0) 0.0 - 6500.0 (F15.13=1) 0 - 65000 (F15.13=2)	s	15.00	●
F00.15	Deceleration Time 1	0.00 - 650.00 (F15.13=0) 0.0 - 6500.0 (F15.13=1) 0 - 65000 (F15.13=2)	s	15.00	●
F00.16	Maximum Frequency	1.00 - 600.00	Hz	50.00	○
F00.17	Upper Limit Frequency Control Options	0: Set through F00.18 1: AI1 2: AI2 3~5: Not Used 6: Upper Limit Frequency Communication Percentage Setting 7: Upper Limit Frequency Communication Direct Setting		0	○
F00.18	Upper Limit Frequency	Lower Limit Frequency F00.19 - Maximum Frequency F00.16	Hz	50.00	●
F00.19	Lower Limit Frequency	0.00 - Upper Limit Frequency F00.18	Hz	0.00	●
F00.20	Running Direction	0: Forward 1: Reverse		0	●
F00.21	Reverse Control	0: Permit Forward/Reverse 1: Prohibit Reverse		0	○
F00.22	F/R Deadband Time	0.00 - 650.00	s	0.00	●
F00.23	Carrier Frequency	1.0~16.0 (A90-4T1R5B~A90-4T9R4B) 1.0~10.0 (A90-4T013B~A90-4T017B) 1.0~8.0 (A90-4T025B~A90-4T110) 1.0~6.0 (A90-4T150~A90-4T304)	kHz	4.0 (A90-4T017B and smaller) 2.0	●
F00.24	Automatic Adjustment of Carrier Wave	0: Disabled 1: Enabled 1 2: Enabled 2		1	○
F00.25	Carrier Frequency Noise Suppression	0: Disabled 1: Enabled		0	○
F00.27	Noise Suppression Intensity	10 - 150	Hz	100	●

A90 series Inverter User Guide

F00.28	Motor Parameter Group Options	0: Motor 1 Parameter 1: Motor 2 Parameter		0	○
F00.29	User Password	0 - 65535		0	○
F00.30	Inverter Type	0: Heavy duty 1: Normal duty		0	○
F01	Motor 1 Parameter				
F01.00	Motor Type	0: Common Induction Motor 1: Variable speed Induction Motor 2: Permanent Magnet Synchronous Motor		0	○
F01.01	Motor Rated Power	0.10~650.00	kW	Model related	○
F01.02	Motor Rated Voltage	50~2000	V		○
F01.03	Motor Rated Current	0.01 - 600.00 (Motor Rated Power ≤ 75 kW) 0.1 - 6000.0 (Motor Rated Power >75 kW)	A		○
F01.04	Motor Rated Frequency	0.01~600.00	Hz		○
F01.05	Motor Rated Speed	1~60000	rpm		○
F01.06	Motor Winding Connection	0: Y 1: Δ		Model related	○
F01.07	Motor Rated Power Factor	0.600~1.000			○
F01.34	Motor Parameter Autotune	00: No Autotune 01: Stationary Autotune of Asynchronous motor 02: Rotational Autotune of Asynchronous motor 11: Stationary Autotune of Synchronous Motor 12: Rotational Autotune of Synchronous Motor		00	○
F02	Input Terminal Function Group				
F02.00	X1 Digital Input Function	0: No Function 1: Run Terminal "RUN"		1	○
F02.01	X2 Digital Input Function	2: Terminal R/F 3: 3-Wire Sequence Stop Control		2	○
F02.02	X3 Digital Input Function	4: Forward JOG (FJOG) 5: Reverse JOG (RJOG)		11	○
F02.03	X4 Digital Input Function	6: Terminal UP 7: Terminal DOWN		12	○
F02.04	X5 Digital Input Function	8: Clear UP/Down Offset 9: Coast to Stop		13	○
F02.05	X6 Digital Input Function	10: Fault Reset 11: Preset Speed Terminal 1		10	○
F02.07	A11 Digital Input Function	12: Preset Speed Terminal 2 13: Preset Speed Terminal 3		0	○
F02.08	A12 Digital Input Function	14: Preset Speed Terminal 4 The other options are shown in Table 9-2. Digital Input Terminal Functions		0	○

A90 series Inverter User Guide

F02.15	Positive/Negative Logic 1 of Digital Input Terminal	D7	D6	D5	D4	D3	D2	D1	D0	**0 00000	○	
		*	*	X6	X5	X4	X3	X2	X1			
		0: Positive Logic, Enabled at On/Disabled at Off 1: Negative Logic, Disabled at On/Enabled at Off										
F02.16	Positive/Negative Logic 2 of Digital Input Terminal	D7	D6	D5	D4	D3	D2	D1	D0	*** ***00	○	
		*	*	*	*	*	*	AI2	AI1			
		0: Positive Logic, Enabled at On/Disabled at Off 1: Negative Logic, Disabled at On/Enabled at Off										
F02.17	Filter Times of Digital Input Terminal	0-100, 0 for No Filter, n for sampling once every n ms								2	○	
F02.18	X1 ON Delay Time	0.000~30.000								s	0.000	●
F02.19	X1 OFF Delay Time	0.000~30.000								s	0.000	●
F02.20	X2 ON Delay Time	0.000~30.000								s	0.000	●
F02.21	X2 OFF Delay Time	0.000~30.000								s	0.000	●
F02.22	X3 ON Delay Time	0.000~30.000								s	0.000	●
F02.23	X3 OFF Delay Time	0.000~30.000								s	0.000	●
F02.24	X4 ON Delay Time	0.000~30.000								s	0.000	●
F02.25	X4 OFF Delay Time	0.000~30.000								s	0.000	●
F02.31	Analog Input Function	Ones Place: AI1 0: Analog Input 1: Digital Input (0 for less than 1V, 1 for over 3V, same to the last time for 1V-3V) Tens Place: AI2 0: Analog Input 1: Digital input (the same as above)									00D	○
F02.32	Analog Input Curve Options	Ones Place: AI1 Curve 0: Curve 1 1: Curve 2 2: Curve 3 3: Curve 4 Tens Place: AI2 Curve 0: Curve 1 1: Curve 2 2: Curve 3 3: Curve 4									10D	○
F02.33	Minimum Input of Curve 1	0.00~F02.35								V	0.10	●
F02.34	Setting Corresponding to Minimum Input of Curve 1	-100.0~+100.0								%	0.0	●

A90 series Inverter User Guide

F02.35	Maximum Input of Curve 1	F02.33~10.00	V	9.90	●
F02.36	Setting Corresponding to Maximum Input of Curve 1	-100.0~+100.0	%	100.0	●
F02.37	Minimum Input of Curve 2	0.00~F02.39	V	0.10	●
F02.38	Setting Corresponding to Minimum Input of Curve 2	-100.0~+100.0	%	0.0	●
F02.39	Maximum Input of Curve 2	F02.37~10.00	V	9.90	●
F02.40	Setting Corresponding to Maximum Input of Curve 2	-100.0~+100.0	%	100.0	●
F02.41	Minimum Input of Curve 3	0.00~F02.43	V	0.10	●
F02.42	Setting Corresponding to Minimum Input of Curve 3	-100.0~+100.0	%	0.0	●
F02.43	Input of Inflexion 1 of Curve 3	F02.41~F02.45	V	2.50	●
F02.44	Setting Corresponding to Input of Inflexion 1 of Curve 3	-100.0~+100.0	%	25.0	●
F02.45	Input of Inflexion 2 of Curve 3	F02.43~F02.47	V	7.50	●
F02.46	Setting Corresponding to Input of Inflexion 2 of Curve 3	-100.0~+100.0	%	75.0	●
F02.47	Maximum Input of Curve 3	F02.45~10.00	V	9.90	●
F02.48	Setting Corresponding to Maximum Input of Curve 3	-100.0~+100.0	%	100.0	●
F02.57	A11 Filter Time	0.00~10.00	s	0.10	●
F02.58	A12 Filter Time	0.00~10.00	s	0.10	●
F02.61	AD Sampling Hysteresis	2~50		2	○

A90 series Inverter User Guide

F03		Output Terminal Function Group										
F03.00	Y1 Output Function	0: No Function									1	○
F03.02	R1 Output Function	Multifunction digital output terminal, see Table 9-3									7	○
F03.05	Output Signal Type	D7	D6	D5	D4	D3	D2	D1	D0		*** **0*0	○
		*	*	*	*	*	R1	*	Y1			
F03.06	Positive/Negative Logic of Digital Output	0: Level signal				1: Single pulse					*** **0*0	○
		D7	D6	D5	D4	D3	D2	D1	D0			
		*	*	*	*	*	R1	*	Y1			
		0: Positive Logic, Enabled at On/Disabled at Off 1: Negative Logic, Disabled at On/Enabled at Off										
F03.08	Output Status Control at JOG	D7	D6	D5	D4	D3	D2	D1	D0		00000	○
		*	*	*	RE	FD	FDT	FA	RU			
		0: Enabled at JOG 1: Disabled at JOG										
F03.09	Y1 ON Delay Time	0.000~30.000								s	0.000	●
F03.10	Y1 OFF Delay Time	0.000~30.000								s	0.000	●
F03.13	R1 ON Delay Time	0.000~30.000								s	0.000	●
F03.14	R1 OFF Delay Time	0.000~30.000								s	0.000	●
F03.17	Y1 single pulse Output Time	0.001~30.000								s	0.250	●
F03.19	R1 single pulse Output Time	0.001~30.000								s	0.250	●
F03.21	Analog Output M1	0: Running Frequency (absolute value) Multi-function analog output terminals, see Table 9-4									0	○
F03.27	M1 Output Offset	-100.0~100.0								%	0.0	●
F03.28	M1 Output Gain	-10.00~10.00									1.00	●
F03.31	PLC output terminal control logic selection	D7	D6	D5	D4	D3	D2	D1	D0		**0*0	●
		*	*	*	*	*	R1	*	Y1			
		0: no output 1: output										

Table 9-2 Digital input terminal functions

Set value	function	Set value	function
0	No Function	26	Frequency Source Switching
1	Run Terminal "RUN"	27	Clear Timed Running time
2	Terminal "R/F"	28	Switch between Speed Control and Torque Control
3	3-Wire Sequence Stop Control	29	Torque Control Disabled
4	Forward JOG (FJOG)	30	Switch between Motor 1 and Motor 2
5	Reverse JOG (RJOG)	31	Simple PLC Status Reset
6	Terminal UP	32	Simple PLC Time Pause
7	Terminal DOWN	34	Counter Input (≤250Hz)
8	Clear UP/Down Offset	36	Counter Clear
9	Coast to Stop	37	Length Counter Input (≤250Hz)

A90 series Inverter User Guide

10	Fault Reset	39	Length Clear
11	Preset Speed Terminal 1	41	Process PID Pause
12	Preset Speed Terminal 2	42	Process PID Integral Pause
13	Preset Speed Terminal 3	43	PID Parameter Switch
14	Preset Speed Terminal 4	44	PID Positive/Negative Action
15	Preset PID Terminal 1	45	Stop and DC Brake
16	Preset PID Terminal 2	46	DC Brake at Stop
17	Preset Torque Terminal 1	47	Immediate DC Brake
18	Preset Torque Terminal 2	48	Fastest Ramp-To-Stop
19	Acceleration/Deceleration Time Terminal 1	50	External Stop command
20	Acceleration/Deceleration Time Terminal 2	51	Switch Main Frequency Source to Digital Frequency F00.07
21	Acceleration/Deceleration Disabled	52	Switch Main Frequency Source to AI1
22	Operation Pause	53	Switch Main Frequency Source to AI2
23	External Fault Input	56	Switch Main Frequency Source to Communication Setting
24	Switch Run Command to Keypad	57	Inverter Enabled
25	Switch Run Command to Communication	69	Prohibit Reverse

Table 9-3 Digital Output Terminal Functions

Set value	function	Set value	function
0	No Function	17	Motor Overload Pre-alarming
1	Inverter Running	18	Inverter Overheating Pre-Alarm
2	Frequency Arrive Range (FAR)	19	PID Feedback Upper Limit Reach
3	Output Frequency Detection Range FDT1	20	PID Feedback Lower Limit Reach
4	Output Frequency Detection Range FDT2	21	Analog input Level Detection ADT1
5	Reverse running (REV)	22	Analog input Level Detection ADT2
6	Jogging	24	Undervoltage condition
7	Inverter Fault	26	Set Time Reach
8	Inverter Ready(READY)	27	Run at Zero Speed
9	Upper Limit Frequency Reach	38	Off Loading
10	Lower Limit Frequency Reach	47	PLC output
11	Current Limit Enabled	59	Sleep indicator
12	Overvoltage Stall Enabled	69	FDT1 Lower Bound (Pulse)
13	Simple PLC Cycle Finished	70	FDT2 Lower Bound (Pulse)
14	Set Count Value Reach	71	FDT1 Lower Bound (Pulse, Invalid when JOG)
15	Designated Count Value Reach	72	FDT1 Lower Bound (Pulse, Invalid when JOG)
16	Length Reach		

Table 9-4 Analog Output Terminal Functions

Set value	function	Set value	function
0	Running Frequency (absolute value)	15	Length Value
1	Set Frequency (absolute value)	16	The PID Output Percentage
2	Output torque (absolute value)	18	PID Feedback
3	Set Torque (absolute value)	19	PID Given
4	Output Current	21	Output frequency (actual value)
5	Output Voltage	22	Set frequency (actual value)
6	DC Bus voltage	23	Output current (actual value)
7	Output power	24	Output torque (actual value)
8	All	25	Set torque (actual value)
9	AI2	27	Estimated feedback frequency (actual value)
13	Communication given	28	Synchronous frequency (actual value)
14	The Count Value	29	Acceleration / deceleration output frequency (actual value)

F04 Start/Stop Control Parameter Group					
F04.00	Start Mode	0: Start Directly 1: Speed Tracking Start		0	○
F04.01	Start Frequency	0.00 - 10.00	Hz	0.00	○
F04.02	Start Frequency Retention Time	0.00 - 60.00, Disabled at 0.00	s	0.00	○
F04.03	DC Brake Current at Start	0.0 - 100.0 (100.0= Motor Rated Frequency)	%	100.0	○
F04.04	DC Brake Time at Start	0.00 - 30.00	s	0.00	○
F04.06	Pre-Excitation Current	50.0 - 500.0 (100.0=Idling Current)	%	100.0	○
F04.07	Pre-Excitation Time	0.00 - 10.00	s	0.10	○
F04.08	Speed Tracking Method	Ones Place: the starting frequency 0: Start from Maximum Frequency 1: Start from Stop Frequency 2: Start from Power frequency Tens Place: search direction 0: Search only in command direction 1: current direction can not find the speed then search the reverse direction		01	○
F04.10	Deceleration Time of Speed Tracking	0.1~20.0	s	2.0	○
F04.11	Speed Tracking Current	30.0~150.0 (100.0=Inverter Rated Current)	%	50.0	○
F04.12	Speed Tracking Compensation Gain	0.00~10.00		1.00	○

A90 series Inverter User Guide

F04.14	Acceleration/Deceleration Mode	0: Linear Acceleration/Deceleration 1: continuous S curve 2: intermittent S curve		0	○
F04.15	S Curve Start Section Time at Acceleration	0.00 - System acceleration time/2 (F15.13=0) 0.0 - System acceleration time/2 (F15.13=1) 0 - System acceleration time/2 (F15.13=2)	s	1.00	●
F04.16	S Curve End Section Time at Acceleration	0.00 - System acceleration time/2 (F15.13=0) 0.0 - System acceleration time/2 (F15.13=1) 0 - System acceleration time/2 (F15.13=2)	s	1.00	●
F04.17	S Curve Start Section Time at Deceleration	0.00 - System deceleration time/2 (F15.13=0) 0.0 - System deceleration time/2 (F15.13=1) 0 - System deceleration time/2 (F15.13=2)	s	1.00	●
F04.18	S Curve End Section Time at Deceleration	0.00 - System deceleration time/2 (F15.13=0) 0.0 - System deceleration time/2 (F15.13=1) 0 - System deceleration time/2 (F15.13=2)	s	1.00	●
F04.19	Stop Mode	0: Ramp-To-Stop 1: Coast-to-Stop		0	○
F04.20	DC Brake Start Frequency at Stop	0.00 - Maximum Frequency F00.16	Hz	0.00	○
F04.21	DC Brake Current at Stop	0.0 - 150.0 (100.0= Motor Rated Current)	%	100.0	○
F04.22	DC Brake Time at Stop	0.00 - 30.00, Disabled at 0.00	s	0.00	○
F04.23	DC Brake Field Weakening Time at Stop	0.00 - 30.00	s	0.50	○
F04.24	Magnetic Flux Brake Gain	100 - 150 (100: No Magnetic Flux Brake)		100	○
F04.26	Start Mode after Fault/Coast to Stop	0: by the Mode of F04.00 1: Speed Tracking Start		0	○
F04.27	Terminal Start Command Reconfirmation	0: Not to Confirm 1: Need to Confirm		0	○
F04.29	Zero speed threshold	0.00 - 5.00	Hz	0.25	●

A90 series Inverter User Guide

F04.30	Initial Position Search after Power-on or Fault	0: Disabled 1: Enabled		1	●
F05	V/F Control Parameter Group				
F05.00	V/F Curve Setting	0: Straight Line V/F 1: Multipoint Polyline V/F 2: V/F to the 1.3rd 3: V/F to the 1.7th 4: Square V/F 5: V/F Complete Split Mode (Ud=0, Uq=K*t=Split Voltage Source Voltage) 6: V/F Half-Split Mode (Ud=0, Uq=K*t=F/Fe*2*Split voltage source voltage)		0	○
F05.01	Multipoint VF Frequency Point F1	0.00 - F05.03	Hz	0.50	●
F05.02	Multipoint VF Voltage Point V1	0.0 - 100.0 (100.0= Motor Rated Voltage)	%	1.0	●
F05.03	Multipoint VF Frequency Point F2	F05.01 - F05.05	Hz	2.00	●
F05.04	Multipoint VF Voltage Point V2	0.0 - 100.0	%	4.0	●
F05.05	Multipoint VF Frequency Point F3	F05.03 - Motor Rated Frequency (Reference Frequency)	Hz	5.00	●
F05.06	Multipoint VF Voltage Point V3	0.0 - 100.0	%	10.0	●
F05.07	Voltage Source of V/F Separation Mode	0: Digital Setting of V/F Separation Voltage 1: AI1 2: AI2 3~4: Not used 5: PID 6: Communication Percentage Setting Note: Motor Rated Voltage is 100%		0	○
F05.08	Digital Setting of VF Separation Voltage	0.0 - 100.0 (100.0= Motor Rated Voltage)	%	0.0	●
F05.09	Rise Time of VF Separation Voltage	0.00 - 60.00	s	2.00	●
F05.10	V/F Stator Voltage Drop Compensation Gain	0.00 - 200.00	%	100.00	●
F05.11	V/F Slip Compensation Gain	0.00 - 200.00	%	100.00	●
F05.12	V/F Slip Filter Time	0.00 - 10.00	s	1.00	●

A90 series Inverter User Guide

F05.13	Oscillation Suppression Gain	0 - 20000		100	●
F05.14	Oscillation Suppression End Frequency	0.00 - 600.00	Hz	55.00	●
F05.15	Sagging Control Frequency	0.00 - 10.00	Hz	0.00	●
F05.16	Energy Saving Rate	0.00 - 50.00	%	0.00	●
F05.17	Energy Saving Action Delay Time	1.00 - 60.00	s	5.00	●
F05.18	Compensation Gain of Magnetic Flux of Synchronous Motor	0.00 - 500.00	%	100.00	●
F05.19	Filter Time Constant of Magnetic Flux Compensation of Synchronous Motor	0.00 - 10.00	s	0.50	●
F05.20	VF Separate power supply for a given rate of change	-50.00~50.00	%	0.00	●
F06	Vector Control Parameter Group				
This group of parameters users generally do not need to adjust, please refer to A90 user manual or visit www.sineedrive.com download function table electronic version.					
F07	Protection Function Setting Group				
F07.00	Protection block selection	E20 E22 E13 E06 E05 E04 E07 E08 0: Valid Protection 1: Protection blocked		000 00000	○
F07.01	Motor Overload Protection Gain	0.20~10.00		1.00	●
F07.02	Motor Overload Pre-Alarming Factor	50~100	%	80	●
F07.06	Bus voltage control selection	Ones Place: continuous woking under instantaneous power failure 0: invalid 1: Deceleration 2: Deceleration and stop Tens Place: Overvoltage stall function 0: Disabled 1: Enabled		10	○
F07.07	Overvoltage Stall Control Voltage	110.0~150.0 (380V,100.0=537V)	%	131.0 (703V)	○
F07.08	Action threshold of continuous woking under instantaneous power failure	60.0~Recovery threshold voltage (100.0= Standard bus voltage)	%	76.0	○
F07.09	Recovery threshold of continuous woking under instantaneous power failure	Action threshold voltage~100.0	%	86.0	●
F07.10	Recovery judgment delay time	0.00~100.00	s	0.50	●

A90 series Inverter User Guide

F07.11	Current Limit Control	0: Disabled 1: Enabled Mode 1 2: Enabled Mode 2		2	○
F07.12	Current Limit Level	20.0 - 180.0 (100.0= Inverter Rated Current)	%	150.0	●
F07.13	Rapid Current Limit	0: Disabled 1: Enabled		0	○
F07.14	Fault Retry Times	0 - 20, 0: Fault Retry Disabled		0	○
F07.15	Digital Output Action at Fault Retry	0: Disabled 1: Enabled		0	○
F07.16	Fault Retry Interval	0.01 - 30.00	s	0.50	●
F07.17	Recovery Time of Fault Retry Times	0.01 - 30.00	s	10.00	●
F07.18	Fault Retry setting	E07 E03 E02 E06 E05 E04 0: Permitted 1: Not Permitted		**0 00000	○
F07.19	Stop mode 1 at Fault	E21 E16 E15 E14 E13 E12 E08 E07 0: Coast to Stop 1: Stop as per F04.19		000 00000	○
F07.20	Stop mode 2 at Fault	E28 E27 E25 E23 0: Coast to Stop 1: Stop as per F04.19		*0000	○
F07.21	Offload Protection	0: Disabled 1: Enabled		0	●
F07.22	Offload Detection Level	0.0 - 100.0	%	20.0	●
F07.23	Offload Detection Time	0.0 - 60.0	s	1.0	●
F07.24	Offload Protection setting	0: Coast to Stop 1: Stop as per F04.19 2: Continue to run, the digital output terminal is valid		1	○
F07.27	Automatic Voltage Regulation(AVR)	0: Disabled 1: Enabled 2: Automatic		1	○
F07.28	Stall fault detection time	0.0~6000.0	s	0.0	○
F07.29	The intensity of stall control	0~100	%	100	○
F07.30	Deceleration time of the continuous woking under instantaneous power failure	0.0~300.0	s	20.0	○
F08	Preset Speed and Simple PLC				
F08.00	Preset Speed 1	0.00 - Maximum Frequency F00.16	Hz	0.00	●
F08.01	Preset Speed 2	0.00 - Maximum Frequency F00.16	Hz	5.00	●
F08.02	Preset Speed 3	0.00 - Maximum Frequency F00.16	Hz	10.00	●
F08.03	Preset Speed 4	0.00 - Maximum Frequency F00.16	Hz	15.00	●
F08.04	Preset Speed 5	0.00 - Maximum Frequency F00.16	Hz	20.00	●

A90 series Inverter User Guide

F08.05	Preset Speed 6	0.00 - Maximum Frequency F00.16	Hz	25.00	●
F08.06	Preset Speed 7	0.00 - Maximum Frequency F00.16	Hz	30.00	●
F08.07	Preset Speed 8	0.00 - Maximum Frequency F00.16	Hz	35.00	●
F08.08	Preset Speed 9	0.00 - Maximum Frequency F00.16	Hz	40.00	●
F08.09	Preset Speed 10	0.00 - Maximum Frequency F00.16	Hz	45.00	●
F08.10	Preset Speed 11	0.00 - Maximum Frequency F00.16	Hz	50.00	●
F08.11	Preset Speed 12	0.00 - Maximum Frequency F00.16	Hz	50.00	●
F08.12	Preset Speed 13	0.00 - Maximum Frequency F00.16	Hz	50.00	●
F08.13	Preset Speed 14	0.00 - Maximum Frequency F00.16	Hz	50.00	●
F08.14	Preset Speed 15	0.00 - Maximum Frequency F00.16	Hz	50.00	●
F08.15	Simple PLC Running Mode	0: Stop after Single Running 1: Stop after given Times of Cycles 2. Run at Last Preset Speed after given Times of Cycles 3: Continuous Cycle		0	●
F08.16	Given Times of Cycles	1 - 10000		1	●
F08.17	Simple PLC Memory	Ones Place: Stop Memory selection 0: Disabled (Start from Preset Speed 1) 1: Enabled (Start at last stop) Tens Place: Power Failure Memory 0: Disabled (Start from Preset Speed 1) 1: Enabled (Start at Power Failure)		0	●
F08.18	Simple PLC Time Unit	0: second 1: minute		0	●
F08.19	Setting of Preset Speed 1	Ones Place: Running Direction 0: Forward 1: Reverse Tens Place: Acceleration/Deceleration Time 0: Acceleration/Deceleration Time 1 1: Acceleration/Deceleration Time 2 2: Acceleration/Deceleration Time 3 3: Acceleration/Deceleration Time 4		0	●
F08.20	Running Time of Preset Speed 1	0.0~6000.0	s/min	5.0	●
F08.21	Setting of Preset Speed 2	The parameter setting range is the same as F08.19		0	●
F08.22	Running Time of Preset Speed 2	0.0~6000.0	s/min	5.0	●
F08.23	Running Time of Preset Speed 3	The parameter setting range is the same as F08.19		0	●
F08.24	Running Time of Preset Speed 3	0.0~6000.0	s/min	5.0	●
F08.25	Setting of Preset Speed 4	The parameter setting range is the same as F08.19		0	●

A90 series Inverter User Guide

F08.26	Running Time of Preset Speed 4	0.0~6000.0	s/min	5.0	●
F08.27	Setting of Preset Speed 5	The parameter setting range is the same as F08.19		0	●
F08.28	Running Time of Preset Speed 5	0.0~6000.0	s/min	5.0	●
F08.29	Setting of Preset Speed 6	The parameter setting range is the same as F08.19		0	●
F08.30	Running time of Preset Speed 6	0.0~6000.0	s/min	5.0	●
F08.31	Setting of Preset Speed 7	The parameter setting range is the same as F08.19		0	●
F08.32	Running Time of Preset Speed 7	0.0~6000.0	s/min	5.0	●
F08.33	Setting of Preset Speed 8	The parameter setting range is the same as F08.19		0	●
F08.34	Running Time of Preset Speed 8	0.0~6000.0	s/min	5.0	●
F08.35	Setting of Preset Speed 9	The parameter setting range is the same as F08.19		0	●
F08.36	Running Time of Preset Speed 9	0.0~6000.0	s/min	5.0	●
F08.37	Setting of Preset Speed 10	The parameter setting range is the same as F08.19		0	●
F08.38	Running Time of Preset Speed 10	0.0~6000.0	s/min	5.0	●
F08.39	Setting of Preset Speed 11	The parameter setting range is the same as F08.19		0	●
F08.40	Running Time of Preset Speed 11	0.0~6000.0	s/min	5.0	●
F08.41	Setting of Preset Speed 12	The parameter setting range is the same as F08.19		0	●
F08.42	Running Time of Preset Speed 12	0.0~6000.0	s/min	5.0	●
F08.43	Setting of Preset Speed 13	The parameter setting range is the same as F08.19		0	●
F08.44	Running Time of Preset Speed 13	0.0~6000.0	s/min	5.0	●
F08.45	Setting of Preset Speed 14	The parameter setting range is the same as F08.19		0	●
F08.46	Running Time of Preset Speed 14	0.0~6000.0	s/min	5.0	●
F08.47	Setting of Preset Speed 15	The parameter setting range is the same as F08.19		0	●
F08.48	Running Time of Preset Speed 15	0.0~6000.0	s/min	5.0	●

A90 series Inverter User Guide

F09		PID Function Group			
F09.00	PID Reference Source	0: Digital PID Setting 1: AI1 2: AI2 3~5: Not Used 6: Communication Percentage Setting(Percentage given)		0	○
F09.01	Digital PID Setting (Target pressure setting)	0.0 – PID Setting Feedback Range F09.03		0.0	●
F09.02	PID Feedback Source	1: AI1 2: AI2 3~5: Not Used 6: Communication Percentage Setting		1	○
F09.03	PID Setting Feedback Range(Pressure sensor range)	0.1 - 6000.0		100.0	●
F09.04	PID Positive/Negative Action selection	0: Positive Action 1: Negative Action		0	○
F09.05	Proportional Gain 1	0.00 - 100.00		0.40	●
F09.06	Integral Time 1	0.000 - 30.000, 0.000: No Integral	s	10.000	●
F09.07	Differential Time 1	0.000 - 30.000	ms	0.000	●
F09.08	Proportional Gain 2	0.00 - 100.00		0.40	●
F09.09	Integral Time 2	0.000 - 30.000, 0.000: No Integral	s	10.000	●
F09.10	Differential Time 2	0.000 - 30.000	ms	0.000	●
F09.11	PID Parameter Switching	0: Disabled 1: Switching through Digital Input Terminal 2: Automatic Switching by Offset		0	●
F09.12	PID Parameter Switching Offset 1	0.00 - F09.13	%	20.00	●
F09.13	PID Parameter Switching Offset 2	F09.12 - 100.00	%	80.00	●
F09.14	PID Initial Value	0.00 - 100.00	%	0.00	●
F09.15	PID Initial Value Retention Time	0.00 - 650.00	s	0.00	●
F09.16	Upper Limit of PID Output	F09.17 ~ +100.0	%	100.0	●
F09.17	Lower Limit of PID Output	-100.0 – F09.16	%	0.0	●
F09.18	PID error Limit	0.00 - 100.00, Disabled at 0.00	%	0.00	●
F09.19	PID Differential Limit	0.00 - 100.00	%	5.00	●
F09.20	PID Integral Separation Threshold	0.00 - 100.00, (100.00%=Integral Separation Disabled)	%	100.00	●
F09.21	PID Setting Variation Time	0.000 - 30.000	s	0.000	●

A90 series Inverter User Guide

F09.22	PID Feedback Filter Time	0.000 - 30.000	s	0.000	●
F09.23	PID Output Filter Time	0.000 - 30.000	s	0.000	●
F09.24	Upper Limit Detection Value of PID Feedback Disconnection	0.00 - 100.00 100.00=Feedback Disconnection Disabled	%	100.00	●
F09.25	Lower Limit Detection Value of PID Feedback Disconnection	0.00 - 100.00 0.00=Feedback Disconnection Disabled	%	0.00	●
F09.26	PID Feedback Disconnection Detection Time	0.000 - 30.000	s	0.000	●
F09.27	PID Sleep Control	0: Disabled 1: Enabled, 0Hz running 2: Enabled, Lower Limit Frequency Running 3: Enabled, Shutdown Output		0	●
F09.29	Sleep Delay Time	0.0~6500.0	s	0.0	●
F09.30	Wake up Action Point	0.00 - 100.00 (100.00 corresponds to F09.03)	%	0.00	●
F09.31	Wake up Delay Time	0.0 - 6500.0	s	0.0	●
F09.32	Preset PID Setting 1	0.0 – PID Setting Feedback Range F09.03		0.0	●
F09.33	Preset PID Setting 2	0.0 – PID Setting Feedback Range F09.03		0.0	●
F09.34	Preset PID Setting 3	0.0 – PID Setting Feedback Range F09.03		0.0	●
F09.39	Wake up mode selection	0:Target pressure F09.01 * wake up coefficient 1:Wake up point (F09.30)		0	○
F09.40	Wake up coefficient	0.0 -100.0 (100.0 corresponds to F09.01)	%	90.0	
F09.41	Pipeline overpressure alarm pressure	0.0 ~ pressure sensor range F09.03	bar	6.0	●
F09.42	Overpressure protection delay time	0 ~ 3600 (0 : invalid)	s	3	●
F10	Communication Function Group				
F10.00	Inverter Address	1 - 247, 0 as broadcasting address		1	○
F10.01	Modbus Communication Baud Rate	0: 4800 1: 9600 2: 19200 3: 38400 4: 57600 5: 115200		1	○

A90 series Inverter User Guide

F10.02	Modbus Data Format	0: 1-8-N-1 (1 start bit + 8 data bits + 1 stop bit) 1: 1-8-E-1 (1 start bit + 8 data bits + 1 even parity + 1 stop bit) 2: 1-8-O-1 (1 start bit + 8 data bits + 1 odd parity + 1 stop bit) 3: 1-8-N-2 (1 start bit + 8 data bits + 2 stop bits) 4: 1-8-E-2 (1 start bit + 8 data bits + 1 even parity + 2 stop bits) 5: 1-8-O-2 (1 start bit + 8 data bits + 1 odd parity + 2 stop bits)		0	○
F10.03	Modbus Overtime	0.0 - 60.0, 0.0: Disabled (also works for master - slave system)	s	0.0	●
F10.04	Modbus Response Delay	1 - 20	ms	2	●
F10.05	Master-Slave Communication Function	0: Disabled 1: Enabled		0	○
F10.06	Master-Slave Options	0: Slave 1: Master (Modbus broadcast)		0	○
F10.07	Data Sent by Master	0: Output Frequency 1: Set Frequency 2: Output Torque 3: Set Torque 4: PID Setting 5: Output Current		1	○
F10.08	Receiving Proportionality Factor of Slave	0.00 - 10.00 (Times)		1.00	●
F10.09	Sending Interval of Master	0.000 - 30.000	s	0.200	●
F10.56	RS485write EEPROM	0~10: default for debugging 11: No trigger write to protect EEPROM. Please set 11 after debugging		0	●
F11	User optional parameter group				
This group of parameters users generally do not need to adjust, please refer to A90 user guide or visit www.sinedrive.com download function table electronic version.					
F12	Keypad and Display Function Group				
F12.00	M.K	0: No Function 1: Forward JOG 2: Reverse JOG 3: Forward/Reverse Switch 4: Rapid Stop 5: Coast to Stop 6: Left Shift		1	○

A90 series Inverter User Guide

F12.01	STOP key selection	0: Valid Only at Keypad Control 1: Valid at All Command Channels		1	○
F12.02	Parameter Locking	0: Unlocked 1: All locked except Reference Input 2: All locked except this Parameter		0	●
F12.09	Speed Display Factor	0.01 - 600.00		30.00	●
F12.10	UP/DOWN key Rate	0.00: Automatic Rate 0.01 - 500.00	Hz/s	5.00	○
F12.11	UP/DOWN Offset Clear	0: Not to Clear 1: Clear at Non-Running Status 2: Clear at Disabled UP/DOWN		1	○
F12.12	Power Failure Save of UP/DOWN Offset	0: Disabled 1: Enabled (only at modified offset)		0	○
F12.13	Kilowatt-Hour Meter Clear	0: Not to Clear 1: Clear		0	●
F12.14	Reset to Factory Defaults	0: No Function 1: Reset (exclusive of motor parameter, inverter parameter, manufacturer parameter, running and power-on time record)		0	○
F12.15	Accumulated Power-On Time hours	0~65535	h	XXX	×
F12.16	Accumulated Power-On Time minutes	0~59	min	XXX	×
F12.17	Accumulated Running Time hours	0~65535	h	XXX	×
F12.18	Accumulated Running Time minutes	0~59	min	XXX	×
F12.19	Inverter Rated Power	0.40~650.00	kW	Model related	×
F12.20	Inverter Rated Voltage	60~690	V		×
F12.21	Inverter Rated Current	0.1~1500.0	A		×
F12.33	Display parameter 1 at running	0.00~99.99 (Stop status display parameters 5)		18.00	●
F12.34	Display parameter 2 at running	0.00~99.99 (Stop status display parameters 1)		18.01	●
F12.35	Display parameter 3 at running	0.00~99.99 (Stop status display parameters 2)		18.06	●
F12.36	Display parameter 4 at running	0.00~99.99 (Stop status display parameters 3)		18.08	●
F12.37	Display parameter 5 at running	0.00~99.99 (Stop status display parameters 4)		18.09	●

A90 series Inverter User Guide

F12.41	UP/DOWN cross zero option	0: forbidden 1: allowed		0	○
F12.45	Keypad UP / DOWN function selection	0: forbidden 1: allowed		1	○
F13	Torque Control Parameter Group				
F13.00	Speed/Torque Control	0: Speed Control 1: Torque Control		0	○
F13.01	Torque Reference selection	0: Digital Torque Setting F13.02 1: AI1 2: AI2 3-5: Not Used 6: Communication Percentage Setting (Full ranges of options 1 to 2, correspond to Digital torque setting F13.02) 7: Not Used		0	○
F13.02	Digital Torque Setting	-200.0 - 200.0 (100.0= Motor Rated Torque)	%	100.0	●
F13.03	Preset Torque 1	-200.0 - 200.0	%	0.0	●
F13.04	Preset Torque 2	-200.0 - 200.0	%	0.0	●
F13.05	Preset Torque 3	-200.0 - 200.0	%	0.0	●
F13.06	Torque Control Acceleration/Deceleration Time	0.00 - 120.00	s	0.05	●
F13.08	Upper Limit Frequency of Torque Control	0: Set through F13.09 1: AI1 2: AI2 3-5: Not Used 6: Communication Percentage Setting 7: Direct Communication Setting		0	○
F13.09	Upper Limit Frequency of Torque Control	0.00 - Maximum Frequency F00.16	Hz	50.00	●
F13.10	Upper Limit Frequency Offset	0.00 - Maximum Frequency F00.16	Hz	0.00	●
F13.18	Reverse speed limit	0~100	%	100	●
F13.19	Reverse torque limit	0~1		1	●
F14	Motor 2 Parameter Group				
This group of parameters users generally do not need to adjust, please refer to A90 user guide or visit www.sineedrive.com download function table electronic version.					
F15	Auxiliary Function				
F15.00	JOG Frequency	0.00 - Maximum Frequency F00.16	Hz	5.00	●
F15.01	JOG Acceleration Time	0.00~650.00 (F15.13=0) 0.0~6500.0 (F15.13=1) 0~65000 (F15.13=2)	s	5.00	●
F15.02	JOG Deceleration Time		s	5.00	●
F15.03	Acceleration Time 2		s	15.00	●
F15.04	Deceleration Time 2		s	15.00	●
F15.05	Acceleration Time 3		s	15.00	●
F15.06	Deceleration Time 3		s	15.00	●
F15.07	Acceleration Time 4		s	15.00	●
F15.08	Deceleration Time 4		s	15.00	●

A90 series Inverter User Guide

F15.09	Acceleration/Deceleration Time Reference Frequency	0: Maximum Frequency F00.16 1: 50.00Hz		0	○
F15.10	Automatic Switching Acceleration and Deceleration Time	0: Disabled 1: Enabled		0	○
F15.11	Switching Frequency between Acceleration Time 1 and Acceleration Time 2	0.00 - Maximum Frequency F00.16	Hz	0.00	●
F15.12	Switching Frequency between Deceleration Time 1 and Deceleration Time 2	0.00 - Maximum Frequency F00.16	Hz	0.00	●
F15.13	Acceleration/Deceleration Time Unit	0: 0.01s 1: 0.1s 2: 1s		0	○
F15.14	Skip Frequency Point 1	0.00 - 600.00	Hz	600.00	●
F15.15	Frequency Skip Range 1	0.00 - 20.00, 0.00: Disabled	Hz	0.00	●
F15.16	Skip Frequency Point 2	0.00 - 600.00	Hz	600.00	●
F15.17	Frequency Skip Range 2	0.00 - 20.00, 0.00: Disabled	Hz	0.00	●
F15.18	Skip Frequency Point 3	0.00 - 600.00	Hz	600.00	●
F15.19	Frequency Skip Range 3	0.00 - 20.00, 0.00: Disabled	Hz	0.00	●
F15.20	Frequency Arrive (FAR) Detection Bandwidth	0.00 - 50.00	Hz	2.50	○
F15.21	Output Frequency Detection Range FDT1	0.00 - Maximum Frequency F00.16	Hz	30.00	○
F15.22	FDT1 Hysteresis	-(Fmax-F15.21)~F15.21	Hz	2.00	○
F15.23	Output Frequency Detection Range FDT2	0.00 - Maximum Frequency F00.16	Hz	20.00	○
F15.24	FDT2 Hysteresis	-(Fmax-F15.23)~F15.23	Hz	2.00	○
F15.25	Analog input Level Detection ADT	0: AI1 1: AI2		0	○
F15.26	Analog input Level Detection ADT1	0.00 - 100.00	%	20.00	●
F15.27	ADT1 Hysteresis	0.00 - F15.26 (Monotonic Downward is active)	%	5.00	●
F15.28	Analog Input Level Detection ADT2	0.00 - 100.00	%	50.00	●
F15.29	ADT2 Hysteresis	0.00 - F15.28 (Monotonic Downward is active)	%	5.00	●
F15.30	Dynamic Brake	0: Disabled 1: Enabled		0	○
F15.31	Dynamic Brake Operation Voltage	110.0~140.0 (380V, 100.0%=537V)	%	125.0 (671V)	○

A90 series Inverter User Guide

F15.32	Brake Duty Ratio	20 - 100 (100 means that duty ratio is 1)	%	100	●
F15.33	Running Mode of Set Frequency Lower Than Lower Limit Frequency	0: Run at Lower Limit Frequency 1: Stop 2: Run at Zero Speed		0	○
F15.34	Fan Control	0: Run at Energization 1: Run at Start 2: Run at Intelligent Temperature Control		2	○
F15.35	Over modulation Intensity	1.00 - 1.10		1.05	●
F15.39	Terminal Jog Priority	0: Disabled 1: Enabled		0	○
F15.40	Deceleration Time at Rapid Stop	0.00 - 650.00 (F15.13=0) 0.0 - 6500.0 (F15.13=1) 0 - 65000 (F15.13=2)	s	1.00	●
F15.68	Power Price	0.00~100.00		1.00	○
F15.69	Load Factor at Power Frequency	30.0~200.0	%	90.0	○
F16 Customized Function Group					
F16.00	Industry Application	0: General purpose 1: Application of Air compressor 2: Applications of extruder 3: Application of pump 4: Application of fan		0	○
F16.01	Set Length	1~65535(F16.13=0) 0.1~6553.5(F16.13=1) 0.01~655.35(F16.13=2) 0.001~65.535(F16.13=3)	m	1000	●
F16.02	Pulse Count Per Meter	0.1 - 6553.5		100.0	●
F16.03	Set Count Value	F16.04 - 65535		1000	●
F16.04	Designated Count Value	1 - F16.03		1000	●
F16.05	Set Timed Running time	0.0 - 6500.0, 0.0: Disabled	min	0.0	●
F16.06	Agent Password	0 - 65535		0	○
F16.07	Set Accumulated Power-On Time Reach	0 - 65535, 0: Power-on Reach Time Protection Disabled	h	0	○
F16.08	Set Accumulated Running time Reach	0 - 65535, 0: Running time Reach Protection Disabled	h	0	○
F16.10	The percentage of analog output when the count value is zero	0.00~100.00	%	0.00	○
F16.11	The percentage of analog output when the count value is the setting count value	0.00~100.00	%	100.00	○

A90 series Inverter User Guide

F16.13	Set Resolution Of The Length	0:1m 1:0.1m 2:0.01m 3:0.001m			0	○		
F17	Virtual I/O Function Group							
This group of parameters users generally do not need to adjust, please refer to A90 user guide or visit www.sinedrive.com download function table electronic version.								
F18	Monitoring Parameter Group							
F18.00	Output Frequency	0.00 - Upper Limit Frequency		Hz	XXX	×		
F18.01	Set Frequency	0.00 - Maximum Frequency F00.16		Hz	XXX	×		
F18.03	Estimated Feedback Frequency	0.00 - Upper Limit Frequency		Hz	XXX	×		
F18.04	Output Torque	-200.0 - 200.0		%	XXX	×		
F18.05	Torque Setting	-200.0 - 200.0		%	XXX	×		
F18.06	Output Current			A	XXX	×		
F18.07	Output Current Percentage	0.0 - 300.0 (100.0= Inverter Rated Current)		%	0.0	×		
F18.08	Output Voltage	0.0 - 690.0		V	XXX	×		
F18.09	DC bus Voltage	0 - 1200		V	XXX	×		
F18.10	Simple PLC Running Times	0 - 10000			XXX	×		
F18.11	Simple PLC Running Stage	1 - 15			XXX	×		
F18.12	PLC Running Time of Present Stage	0.0 - 6000.0			XXX	×		
F18.14	Load Speed	0 - 65535		rpm	XXX	×		
F18.15	UP/DOWN Offset Frequency	0.00 - 2*Maximum Frequency F00.16		Hz	XXX	×		
F18.16	PID Setting	0.0 – PID Maximum Range			XXX	×		
F18.17	PID Feedback	0.0 – PID Maximum Range			XXX	×		
F18.18	Kilowatt-Hour Meter, MWh	0 - 65535		MWh	XXX	×		
F18.19	Kilowatt-Hour Meter, kWh	0.0 - 999.9		kWh	XXX	×		
F18.20	Output Power	0.00 - 650.00		kW	XXX	×		
F18.21	Output Power Factor	-1.000 - 1.000			XXX	×		
F18.22	Digital Input Terminal Status 1	X5	X4	X3	X2	X1	XXX	×
		0/1	0/1	0/1	0/1	0/1		
F18.23	Digital Input Terminal Status 2	*	AI2	AI1	*	X6	XXX	×
		*	0/1	0/1	*	0/1		
F18.25	Output Terminal Status	*	*	R1	*	Y1	XXX	×
		*	*	0/1	*	0/1		
F18.26	AI1	0.0~100.0		%	XXX	×		
F18.27	AI2	0.0~100.0		%	XXX	×		
F18.33	Count Value	0~65535			XXX	×		

A90 series Inverter User Guide

F18.34	Actual Length	0~65535	m	XXX	×
F18.35	Remaining Time of Timed Run	0.0~6500.0	min	XXX	×
F18.39	VF Separation Target Voltage	0~690	V	XXX	×
F18.40	VF Separation Output Voltage	0~690	V	XXX	×
F18.51	PID Output	-100.0~100.0	%	XXX	×
F18.60	Inverter temperature	-40~200	°C	0	×
F18.67	Cumulative Energy Savings MWH	0~65535	MW h	XXX	×
F18.68	Cumulative Energy Savings KWH	0.0~999.9	kWh	XXX	×
F18.69	Cumulative Savings In Electricity Bills (*1000)	0~65535		XXX	×
F18.70	Cumulative Savings In Electricity Bills	0.0~999.9		XXX	×
F18.71	Power Consumption at Power Frequency MWH	0~65535	MW h	XXX	×
F18.72	Power Consumption at Power Frequency KWH	0.0~999.9	kWh	XXX	×
F19	Fault Record Group				
F19.00	Last Fault Type	0: No Fault Refer to Chapter 6 Troubleshooting		0	×
F19.01	Output Frequency at Fault	0.00 - Upper Limit Frequency	Hz	0.00	×
F19.02	Output Current at Fault	0.00 - 650.00 (Motor Rated Power ≤ 75kW) 0.0 - 6500.0 (Motor Rated Power >75kW)	A	0.00	×
F19.03	Bus Voltage at Fault	0 - 1200	V	0	×
F19.04	Running Mode at Fault	0: Stopped 1: Forward Acceleration 2: Reverse Acceleration 3: Forward Deceleration 4: Reverse Deceleration 5: Forward Constant Speed 6: Reverse Constant Speed		0	×
F19.05	Working Time at Fault		h	0	×
F19.06	Last Fault Type	See F19.00 Parameter Description		0	×
F19.07	Output Frequency at Fault		Hz	0.00	×
F19.08	Output Current at Fault		A	0.00	×
F19.09	Bus Voltage at Fault		V	0	×
F19.10	Running Mode at Fault	See F19.04 Parameter Description		0	×
F19.11	Working Time at Fault		h	0	×
F19.12	Types of Last Two Faults	See F19.00 Parameter Description		0	×
F19.13	Output Frequency at Fault		Hz	0.00	×
F19.14	Output Current at Fault		A	0.00	×
F19.15	Bus Voltage at Fault		V	0	×
F19.16	Running Mode at Fault	See F19.04 Parameter Description		0	×
F19.17	Working Time at Fault		h	0	×

10 application macro

10.1 Applications macro Introduction

For the following applications, according to the configuration of some customers, some parameters' defaults were changed. After selecting the application macro and wiring according to the wiring diagram provided, customers can accomplish the application easily.

No.	Function	Range	Unit	Default	Type
F16.00	Macro selection	0: General purpose 1: Air compressor application 2: Extrusion machine applications 3: Pump applications 4: Fan application		0	○

Note: After selecting macro, you need select F12.14 = 1 to restore the factory value, then the application macro work.

10.2 Applicable occasions of macro

Application macro	Applicable occasions
General purpose	Keypad control running, general purpose inverter. The terminal factory configuration see Chapter III control circuit standard wiring diagram
Air compressor application	Air compressor control logic by the controller, inverter only works as the speed control executor. Configuration factory parameters according to 4-20mA current signal as the frequency reference.
Extrusion machine applications	Analog input as frequency reference, terminal control start and stop. Can be used for extruder and feed motor control.
Pump applications	Contains a sleep, wake-up function of constant pressure water supply applications, can control the variable speed pump and sleep pump. Digital target pressure, 4-20mA pressure transmitter as a pressure feedback.
Fan application	Including manual operation/ automatic operation switch, speed tracking start, continuous working under instantaneous power failure. This is a normal duty application. When the X2 terminal is enabled, the manual operation enabled

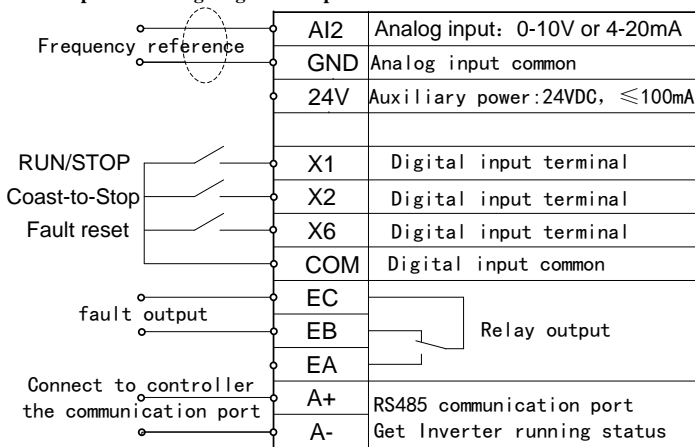
10.3 Application of the corresponding wiring diagram and parameter list**10.3.1 Compressor wiring diagram and parameter list****The parameter list of Air compressor application macro**

F16.00=1: Air compressor application, After restore the factory value, Parameters shown in the following table:

No.	Function	range	Unit	Default
F00.01	Drive control mode of motor 1	0: V / F control (VVF) (asynchronous machine) 1: Sensorless vector control (SVC) (synchronous machine)		0
F00.02	Command source selection	0: Keypad control 1: Terminal control 2: communication control		0
F00.04	Main Frequency Source A Options	2: AI2*		2
F00.14	Acceleration time 1		s	25.00
F00.15	Deceleration time 1		s	30.00
F00.16	Maximum frequency		Hz	50.00
F00.18	Upper limit frequency		Hz	50.00
F00.19	Lower limit frequency		Hz	30.00
F00.21	Reverse control	1: Prohibit Reverse		1
F00.23	Carrier Frequency *	4.0kHz(A90-4T017B and the lower) others are 2.0kHz	kHz	Model related
F00.24	Automatic Adjustment of Carrier Wave	0: Disabled		0

A90 series Inverter User Guide

F01.00	Motor Type	0: Common Asynchronous motor 1: Inverter Asynchronous motor 2: Permanent Magnet Synchronous Motor		0
F02.00	X1 Digital Input Function	1: Run Terminal "RUN"		1
F02.01	X2 Digital Input Function	9: Coast to Stop		9
F02.37	Minimum Input of Curve 2	Analog input AI2, minimum	V	2.10
F02.38	Setting Corresponding to Minimum Input of Curve 2	Minimum corresponds to the frequency ratio	%	0.0
F02.39	Maximum Input of Curve 2	Analog input AI2 maximum	V	9.90
F02.40	Setting Corresponding to Maximum Input of Curve 2	The maximum input corresponds to the frequency ratio	%	100.0
F03.00	Y1 Output Function	1: Inverter Running		1
F03.02	R1 Output Function	7: Inverter Fault		7
F04.00	Start Mode	0: Start Directly		0
F04.19	Stop Mode	0: Ramp-To-Stop		0
F05.00	V / F curve setting	0: Straight line V / F curve		0
F07.01	Motor overload protection gain	0.2~10.00		1.02
F07.02	Motor overload warning coefficient	50~100		100

Note 1: The above table is the asynchronous motor air compressor application parameter table, When the motor type is a synchronous motor, Please set F01.00 = 2 (permanent magnet synchronous motor),

F00.01 = 1 (SVC control), F00.23 = 4.0 kHz (carrier frequency), And according to the motor parameters set F00.16 (maximum frequency), F00.18 (upper limit frequency), F00.19 (lower limit frequency).

10.3.2 Extruder application macro wiring diagram and parameter list

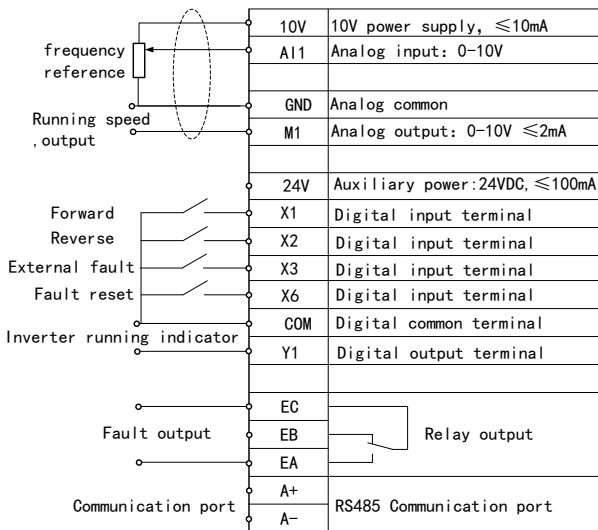

The parameter list of Extruder application macro

F16.00=2: Extruder application, restore the factory value, the parameters shown in the following table:

No.	Function	range	Unit	Default
F00.02	Command Source Options	0: Keypad Control 1: Terminal Control 2: Communication Control		0
F00.03	Terminal Control Mode Options	1: Terminal RUN for forward, F/R for reverse		1
F00.04	Main Frequency Source A Options	1: AI1		1
F00.14	Acceleration Time 1		s	25.00
F00.15	Deceleration Time 1		s	30.00
F00.16	Maximum Frequency		Hz	50.00
F00.18	Upper Limit Frequency		Hz	50.00
F00.19	Lower Limit Frequency		Hz	0.00
F02.00	X1 Digital Input Function	1: Run Terminal "RUN"		1
F02.01	X2 Digital Input Function	2: Terminal R/F		2
F02.02	X3 Digital Input Function	23: External Fault Input		23
F05.00	V/F Curve Setting	1: Multi-Dot Polyline V/F		1
F05.02	Multipoint VF Voltage Point V1	0.0 - 100.0 (100.0= Motor Rated Voltage)	%	2.0
F05.04	Multipoint VF Voltage Point V2	0.0 - 100.0 (100.0= Motor Rated Voltage)	%	5.5
F05.10	V/F Stator Voltage Compensation Gain	0.00-200.00 (0.00 invalid)	%	0.00
F05.11	V/F Slip Compensation Gain	0.00-200.00 (0.00 invalid)	%	0.00

10.3.3 The corresponding wiring diagram of the pump application macro

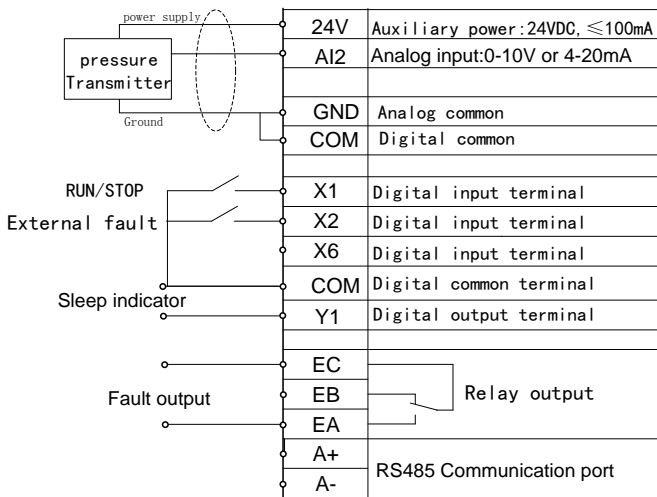

The parameter list of Pump application macro

F16.00=3:Pump application, restore the factory value, the parameters are as follows:

Function:the process PID, continuous working under instantaneous power failure, fault retry, sleep and wake up, pipe network overpressure alarm function

Water pressure conversion relationship:

$$1\text{bar}=0.1\text{Mpa}=100\text{kPa}\approx 1\text{kg/cm}^2$$

No.	Function	range	Unit	Default
F00.02	Command Source Options	0: Keypad Control 1: Terminal Control 2: Communication Control		0
F00.05	Auxiliary Frequency Source B Options	10: Process PID		10
F00.06	Frequency Source Options	1: Auxiliary Frequency Source B		1
F00.14	Acceleration Time 1		s	25.00
F00.15	Deceleration Time 1		s	30.00
F00.16	Maximum Frequency		Hz	50.00
F00.18	Upper Limit Frequency		Hz	50.00
F00.19	Lower Limit Frequency (Sleep frequency)		Hz	5.00
F00.21	Reverse Control	1: Prohibit Reverse		1
F00.30	Load Type	1: Nomal duty		1
F02.00	X1 Digital Input Function	1: Run Terminal "RUN"		1
F02.01	X2 Digital Input Function	23: External Fault Input With the external water shortage signal terminal		23

A90 series Inverter User Guide

F02.37	Minimum Input of Curve 2	Analog input AI2 minimum	V	2.10
F02.38	Setting Corresponding to Minimum Input of Curve 2	Minimum corresponds to the frequency ratio	%	0.0
F02.39	Maximum Input of Curve 2	Analog input AI2 maximum	V	9.90
F02.40	Setting Corresponding to Maximum Input of Curve 2	The maximum input corresponds to the frequency ratio	%	100.0
F03.00	Y1 Output Function	59: Dormancy Instructions A relay that controls the dormant pump		59
F03.02	R1 Output Function	7: Inverter Fault		7
F05.00	V/F Curve Setting	4: Square V/F		4
F07.06	Bus Voltage Control Options	Ones Place: continuous working under instantaneous power failure 0: Invalid 1: valid Tens Place: Overvoltage stall function selection 1: valid		11
F07.14	Fault Retry Times	0 – 20, 0: Fault Retry Disabled Some faults allow retry to start 5 times		5
F07.16	Failure retry interval	30s	s	30.00
F09.00	PID Setting Source	0: Digital PID Setting F09.01		0
F09.01	Target pressure setting	0.0 ~ pressure sensor range F09.03	bar	1.0
F09.02	PID Feedback Source	2: AI2		2
F09.03	Pressure sensor range	0.1 ~ 6000.0	bar	10.0
F09.27	Sleep Option	0: Disabled 3: Shutdown Output		3
F09.29	Sleep Delay Time	0.0 ~ 6500.0	s	5.0
F09.30	Wake up Point	0.00 - 100.00 (100.00 corresponds to F09.03)	%	9.00
F09.31	Wake up Delay Time	0.0 ~ 6500.0	s	5.0
F09.39	Wake up mode selection	0: Target pressure F09.01 * wake up coefficient 1: Wake up point (F09.30)		0
F09.40	Wake up coefficient	0.0 - 100.0 (100.0 corresponds to F09.01)	%	90.0
F09.41	Pipeline overpressure alarm pressure	0.0 ~ pressure sensor range F09.03	bar	6.0
F09.42	Overpressure protection action time	0 ~ 3600 (0 disabled)	s	3
F18.17	PID Feedback display	Display the current actual pressure	bar	XXX

10.3.4 The corresponding wiring diagram of the fan application macro

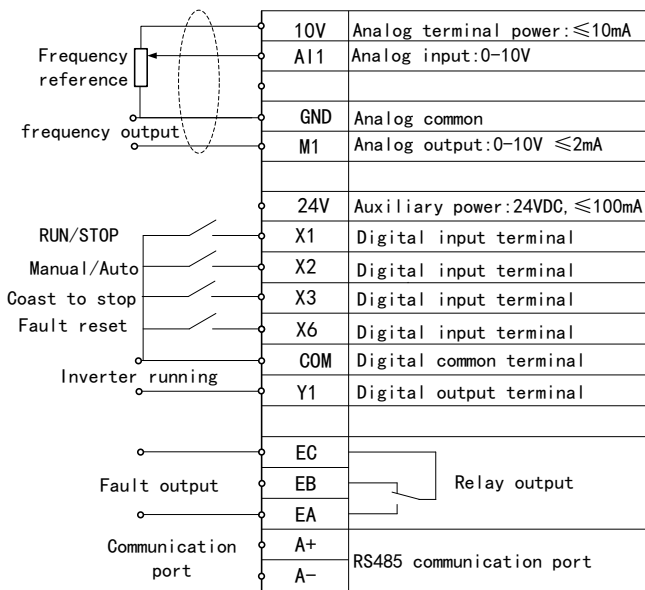

The parameter list of Fan application macro

F100=4:Fan application, After restoring the factory values, the parameters are shown in the following table:

Function: with guide / automatic switching function, speed tracking start, continuous working under instantaneous power failure, general failure retry function. Guide: F0.07 set the operating frequency, the keypad control start and stop; automatic: A11 voltage given frequency, terminal control start and stop.

No.	Function	Range	Unit	Default
F00.02	Command Source Options (Automatic mode)	0: Keypad Control 1: Terminal Control 2: Communication Control		1
F00.04	Main Frequency Source A Options	1: A11 (Automatic mode)		1
F00.07	Digital Frequency reference	Manual mode frequency	Hz	35.00
F00.14	Acceleration Time 1		s	25.00
F00.15	Deceleration Time 1		s	30.00
F00.16	Maximum Frequency		Hz	50.00
F00.18	Upper Limit Frequency		Hz	50.00
F00.19	Lower Limit Frequency		Hz	0.00

A90 series Inverter User Guide

F00.21	Reverse Control	1: Prohibit Reverse		1
F00.30	Load Type	1: Normal Duty		1
F02.00	X1 Digital Input Function	1: Run Terminal “RUN”		1
F02.01	X2 Digital Input Function	24: Switch Run Command to Keypad When the terminal is enabled, switch to manual mode		24
F02.02	X3 Digital Input Function	9: Coast to Stop		9
F03.00	Y1 Output Function	1: Inverter Running		1
F04.00	Start Mode	1: Speed Tracking Start		1
F04.08	Speed Tracking Method	Ones Place: the starting frequency 1: stop frequency Tens Place: search direction 1: current direction can not find the speed then search the reverse direction		11
F04.19	Stop Mode	0: Ramp-To-Stop 1: Coast-to-Stop		1
F05.00	V/F Curve Setting	4: Square V/F		4
F07.06	Bus Voltage Control Options	Ones Place: continuous working under instantaneous power failure 0: Invalid 1: valid Tens Place: Overvoltage stall function selection 1: valid		11
F07.14	Fault Retry Times	0 – 20, 0: Fault Retry Disabled Some failure allows retry to start 5 times		5
F07.16	Fault retry interval	30s	s	30.00
F17.01	VX2 virtual terminal input function selection	51: The main frequency source switch to F00.07		51
F17.09	VX1-VX8 status setting	VX2 status with VY2 output status		00000
F17.28	Virtual output terminal control selection	The VY2 state is determined by the X2 terminal status		00000

Note 2: When the AI2 works as current signal, the S2 switch on control board should be selected ‘I’ mode.

Note 3: To facilitate commissioning, default command source is keypad control, After debugging, Please change to the required command source.

Note 4: Industry application macros can not be guaranteed to meet the needs of all users of the application, therefore, After selecting the application macro, It is also possible to set other parameters.